

ACCULTURATION IN THE BRAHMAPUTRA VALLEY : THE AHOM CASE

NITUL KUMAR GOGOI
DEPARTMENT OF ANTHROPOLOGY

THESIS
SUBMITTED
IN
FULFILMENT OF THE REQUIREMENT FOR THE DEGREE
OF
DOCTOR OF PHILOSOPHY



NORTH-EASTERN HILL UNIVERSITY

SHILLONG

AUGUST, 1995

DS
301.2410954162
G06

NEHU, LIBRARY

Acc. No. 102838
A. S.P. Thakur
D. 15/1/97
Dl. 16/1/2020
Sub.
Ent.
Trans.



पूर्वोत्तर पर्वतीय विश्वविद्यालय
मयूरभंज परिसर, शिल्लॉंग - 793014 (मेघालय)
North-Eastern Hill University
Mayurbhanj Complex, Shillong - 793014 (Meghalaya)

Phone :
Grams : NEHU

CERTIFICATE

This is to certify that the thesis entitled **Acculturation In The Brahmaputra Valley : The Ahom Case.** submitted by Nitul Kumar Goqoi for the degree of Doctor of Philosophy Of the North-Eastern Hill University, Shillong, embodies the record of original investigation carried out by him under my supervision. He has been duly registered and the thesis presented is worthy of being considered for the award of Ph.D Degree. This work has not been submitted for any Degree of any other University.

P.K. Misra
29.7.95

(Prof. P.K. Misra)

Supervisor

CONTENTS

| | | Page No. |
|--------------|---|----------|
| PREFACE | | i-ii |
| CHAPTER I | Introduction | 1-12 |
| CHAPTER II | Materials & Methods | 13-18 |
| CHAPTER III | The Ahoms : A Historical Perspective A & B | 19-39 |
| CHAPTER IV | The Ahoms Today I | 40-88 |
| CHAPTER V | The Ahoms Today II | 89-115 |
| CHAPTER VI | Discussion | 116-147 |
| BIBLIOGRAPHY | | 148-155 |
| APPENDIX | | |

PREFACE

The objective of the present thesis is to examine those processes which the Ahoms had to undergo to become what they are today. 'What they are today' has been a perennial question of inquiry for the Ahoms as an ethnic group. This has been an academic interest also for a long period of time. Different views have been presented to label the group as 'totally assimilated' into a larger identity. Such views suggest a total loss of identity and a structural change within the group. To an equal extent, views advocating a 'static identity' of being the Tai are also heard, which argue in favour of retention of tradition and structural stability. Much of such views are superficial in nature and are mostly presented on the basis of existing historical literatures. No in depth ethnohistorical works are available to negate or support either of the views. Therefore it was felt necessary to undertake an ethnohistorical research in order to examine what had actually happened to the Ahoms.

We have tried our best to critically examine every aspect of the 'Ahom culture' on the basis of the empirical data supplemented by secondary sources of information and have endeavoured to present a number of generalizations as students of Anthropology. It is, however, for the other scholars to judge the validity of those generalizations. We do not claim to have said the last word on the Ahoms but believe that we could at least raise certain thought provoking issues and invite the future scholars for further investigation.

I also take this opportunity to acknowledge my indebtedness to my teacher and guide Prof. Promode Kumar Misra, under whose able guidance I completed my research work. I am extremely grateful to Prof. Alope Kumar Ghosh and Dr. Tanka Bahadur Subba for their valuable instructions and advice which I often received from them. I am also grateful to Dr. Raj Kumar Pathak, Head of the department of Anthropology who was consistently supportive throughout my work. Thanks are also due to my friend Dr. Debasish Dutta, St. Edmund's College for drawing the sketches for my thesis.

Finally, I am indeed grateful to my friends for giving me immense support while writing my thesis.

August, 1995.

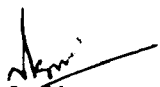
Nitul Kumar Gogoi

CHAPTER I :

INTRODUCTION:

- * Concept
- * Relevance Of the Concept
- * Survey Of Literature
- * Scope Of The Study
- * Hypothesis
- * Objective

INTRODUCTION

The concept :

The word acculturation was widely accepted among American anthropologists as a concept referring to those changes set in motion by the coming together of societies with different cultural conditions (International Encyclopaedia Of the Social Sciences, Vol.1:21-6,1968). This field of investigation was generally referred to by British anthropologists as 'culture contact'. A persistent usage gave the term the meaning of cultural assimilation, or replacement of one set of cultural traits by another, as in references to individuals in contact situation, as more or less 'accultured'.

It developed as an area of anthropological inquiry in 1880s and became a major field of investigation. It appeared first in the writings of the North Americans like W.H Holmes (1886), Franz Boas (1896) and W.J McGee (1898). McGee spoke of 'piratical acculturation' and 'amicable acculturation' meaning transfer and adjustment of customs and condition of contacts between peoples of 'lower-grades' and 'higher-grades' respectively, whereas Boas used it in more general sense to refer to those derived processes of change as a result of which the culture of a region —

becomes similar to one another. Boas's usage gained some support from the German ethnologists like Ehrenreich (1905) and Krickeberge (1910).

Later the North American anthropologists concerned themselves increasingly with studying the phenomena of cultural change resulting from contact between peoples. Initial studies were directed towards the construction of dead cultures as evident from Lewis' (1935) intensive study of Crow Indian culture of the buffalo period. From 1930 onwards, attention shifted to the firsthand observation of the contact between Indians and Anglo Americans and between native Africans and Europeans. Studies like "Changing Culture of an Indian Tribe" by Margaret Mead (1932) and "Reaction to conquest" by Monica Hunter Wilson (1936), among the Pondo and other natives of South Africa were worth mentioning.

Studies by some contemporary scholars like Herskovits (1927), Redfield (1929), Lesser (1933), Schapera (1934), and Spier (1935) made acculturation studies an important interest of anthropologists. A strong thrust could be seen in 1935 when a committee under the chairmanship of Robert Redfield prepared a memorandum called "Outline for the study of Acculturation" (Redfield, Linton and Herskovits 1935). The committee sought to define the field that was —

coming to be called as 'acculturation' and to provide a checklist of topics concerning which data should be gathered if the phenomena defined were to be systematically investigated.

This effort gave birth to a working definition of it which is as follows :

"Acculturation comprehends those phenomena which result when groups of individuals having different cultures come into continuous firsthand contact with subsequent changes in the original cultural pattern of either or both groups" (Redfield, Linton and Herskovits 1936:149).

Efforts were made to identify types and situation of contact, process, psychological mechanism and results. The processes of 'determination', 'selection', and 'integration' were identified respectively, those resulting in the presentation of traits by a 'donor-group' in contact situation, the accepting of traits by a 'receiving group' and 'reaction' recognized the replacement of cultural elements, combination of elements into new wholes, and rejection of elements. All these features, later, became the basis of analysis of acculturation phenomena. In other words "acculturation" was more or less reciprocal, but incomplete. Each people was also likely to be developing new peculiarities even while it was taking over culture from the other" (Kroeber, 1948/1972 : 428-29).

Acculturation and Diffusion :

Acculturation as a concept to study cultural change might at times be seen similar to diffusion. Over the years, diffusion came to mean the analysis of similarities and differences between existing non-literate, and in this sense non-historic cultures. The contacts that presumably took place between peoples had to be constructed, and the reshaping of the borrowed elements inferred from the variations in their forms as manifest in one culture after another. Acculturation, on the other hand, was applied chiefly to instances where transmission of cultural elements could be more fully documented either by study on the spot, or by the use of documentary data, or both. In summary, then, diffusion was the study of achieved cultural transmission; while acculturation was the study of cultural transmission in process (Herskovits 1964:170).

Diffusion studies, by and large, assumed that the contacts had taken place between peoples because of the similarities observed between their cultures at the time they were studied. The reconstruction of the processes, by means of which transmission was made, thus became possible by drawing inference from the nature of the materials. Studies on acculturation, however, had the benefit of historic facts that were known or could be obtained. In most cases,

acculturation research dealt with contacts in the contemporary period. The conditions antecedent to the contact could thus be discovered, the pre-contact cultures of the people party to it could be ascertained, and the present condition of the cultures set down. In some cases, even the personalities involved in influencing the acceptance or rejection of varied elements could be reached. Where documentation was necessary, the welding of ethnographic and historical materials was a matter of cross-disciplinary research, which had given rise to a special technique called the **ethnohistorical method** (Herskovits 1964:171).

In acculturation studies, 'contacts' with the other cultures set the process of cultural-transmission on; and as such, types of contacts between peoples differed in many respects.

1. Contacts may occur between entire populations, or substantial segments of these populations.
2. They may arise from contact between smaller groupings or even individuals.
3. It may be a hostile contact between groups.
4. Between groups of equal or different population sizes.
5. Between groups that differ in the complexity of their material and non-material culture, or the receiving group achieves its contact with new culture in a new habitat.

6. There may be 'contact' through an intermediary group playing the role of 'bridge' or 'buffer' or both at different times between two powerful groups.
7. The 'contact' may not be necessarily continuous and first hand as perceived by Redfield et al.

Acculturation and the Ahoms :

The Ahoms of Assam seemed to fit into the 3rd and 5th types of contact situations. That acculturation is a two way process was beautifully exemplified by the Ahoms who by the first quarter of 13th century had left their original habitat in Yunan, organized themselves politically around 1228 A.D. in Assam. They had tremendous ability of assimilating their neighbours. This was borne out by the chronicles that many a tribe like the Naga, Moran, Barahi, Chutiya, and Kachari were 'assimilated' widely with the Ahom social organization and thus the terms like "Chutiya-Ahom", "Barahi-Ahom", "Kachari-Ahom", "Moran-Ahom", "Naga-Bailung" and "Miri-Sandique", came into being. The process could be called as 'Ahomization' as often referred to by Phukan (1968) and Guha (1987).

In course of time, arising from their new contacts, many changes took place within their culture leading

towards the process of Hinduization that started during the reign of king Sui-dang-pha (Bamuni Konwar 1337-1407), and got accelerated when king Suhummung (1497-1539) brought under his territory the kingdom of the Hinduized Chutiyas and the present district of Nowgong ruled by the Bara-Bhuyans. The shunning of beef eating, giving up of the pile-house for mud-plinth house, forsaking burial practice and accepting the practice of cremation, to mention a few, are the resultant changes that had occurred.

Indira Barua's (1978) work to some extent could be treated as an acculturation study on the Ahoms, though she dealt more with ethnographic data than historical one. All through her thesis she seemed to have tried to see 'Tainess' standing distinctively unique and 'to be Tai' as persisting but latent urge within the community. Her thesis overlooked the possibility of a shift within 'Tainess' in course of such a long historical past.

Rai Sahib Golap Chandra Barua (1930) gave a descriptive account of Tai Ahoms from the earliest time to the end of Ahom rule.

Lila Gogoi (1961) gave a beautiful description of Ahoms vis-a-vis Assamese culture. He dealt with the Ahom's contribution towards the formation of greater Assamese society.

Gogoi again (1985) textualized an outline of Tai Ahom culture in detail. The book was a valuable source of information on Ahom culture from 'historical perspective'.

Jotin Borgohain (1989) dealt with the Ahoms in the history of Assamese culture. R. Buragohain (1988) examined the course of Ahom state formation in mediaeval North-east India. Gohain examined a number of theories in the formation of a state. Gohain (1986) dealt with the social stratifications in the Ahom state formation. In the year 1987, he presented a paper on Brahminical influence in the formation of the Ahom state. Gohain (1993) presented another paper on Integration and inter-ethnic relations in the Ahom state of mediaeval Assam.

K.C. Phukan (1989) presented a paper on Organization of the villages under the Ahom rule. Mumtaza Khatun (1981) wrote about The marriage relations of the Ahom rulers with the neighbouring ruling families, and Debasish Sen (1985) presented a paper on Local influence upon the Ahoms.

Sir Edward Gait (1984) presented a brief political history on Ahoms. He devoted a few pages on the issues like The Rise Of The Ahom Kingdom to The Decay And Fall Of The Ahom Kingdom and The Ahom System Of Government (page 70-246).

Padmeswar Gogoi's (1968) work presented a detail account of their migrational history.

Amalendu Guha (1987) made an inquiry into the Ahom state formation in Medieval Assam where he talked about the Ahoms mode of production which led to the generation of surplus which in turn was responsible for the formation of the state.

Laksmi Devi (1968) made a political study of the Ahoms and their relations with other tribes of the region. In her book, she dealt with the Ahom administrative policies towards the neighbouring tribes during the six hundred years of the Ahom rule in Assam.

B.J Terwiel (1980:vol I&II) gave a detail account of the Tai culture with comparative case studies on other South-east Asian Tais. Terwiel here cited mostly the Khamyangs, Phakeys and Khamtis of Assam and his treatment of the Ahoms was inadequate.

P.C Chowdhury (1966) in his The History Of Civilization Of The People Of Assam To The Twelfth Century A.D., wrote a few lines on the Ahoms.

S.K Chatterjee (1950:33/55-60) devoted a few pages on Ahoms where he wrote that "...They cultivated their language and wrote Buranjis or chronicles in them, a practice which they continued in Assamese after they abandoned Ahom for Assamese". And "...In their political history and their achievements (successful resistance to the Muslims from the west) the Ahoms formed a most important and powerful Indo-mongoloid group in North-eastern India" (ibid:33). He further wrote :

"...The Chutiyas had probably been receiving earlier Thai or Ahom immigrants from the east, and they had become considerably intermixed with them.... They and the other Bodo tribe of the Morans, living by the Dibru river, were conquered by the Ahoms; and the Chutiyas were to some extent absorbed by the Ahoms. The Ahoms, it would appear, were forced to take wives from among their Bodo subjects, and it is thus likely that they approximated more and more with original people. But it was certainly a clear indication of their being a real Herrenvolk in Assam, that they were able to keep their institutions intact, and even to improve them, and held on to their language for five centuries" (ibid:56).

B.K Kakati (1972:3) pointed out that "...Asama, peerless, may be a sanskritization of some earlier formation like Āchām. In Tai (Ahom), Cham means to be defeated, and with the prefix 'A', the formation 'Asam' would mean undefeated. The word 'Asama', first given to the Shans (Ahoms), was later on applied to the country".

S.N Sarma (1966) while dealing with Neo-Vaisnavism mentioned about acceptance and rejection of various forms of Hinduism among the Ahom monarchs .

A. Barua's (1989) article on 'Religious outlook of the Ahoms' presented an idea about their selective adherence to a particular sub-sect of the Hinduism.

Scope of the study :

The above mentioned studies, baring one or two, were mostly historical in nature. Indira Barua's (1978) work was, by and large, an ethnographic account of a village community. Other studies on Ahoms were on political history of the Ahom kingdom. A few of them were devoted to the Tai culture which the Ahoms had brought with them. Very few works dealt with social and cultural change among the Ahoms in a contemporary situation and there was also much less dealing with the issues as to what they retained, what they adopted, what they modified and what they invented in their culture. Each of these issues raised a number of related issues of which their existence as a group was of primary interest to them. Moreover, the domain of cultural change was a vast field of study and the question of cultural change as such, inspite of enormous literature on the subject, remained a perennial question. It was so because of the fact that the problem of change as a process was practically beyond the perception of any time framework.

In the case of the Ahoms acculturation was very important factor. As they came in contact with numerous cultures, both while they were nomadic and also when they settled down. Such contacts undoubtedly made serious impact

on their way of life, some of which they resisted and some were incorporated in their style of life.

Considering the above, it was felt necessary to project the imagination on the contemporary Ahom situation. We propose the following hypothesis to examine the same:

"...In course of their long history the Ahoms synthesized a new culture, in which most of the old values were retained in new forms".

Objective :

In the light of the above discussion, our objective in the present study was to examine the contemporary situation of the Ahoms in a village in the context of the overall history of the Ahoms, and also the contacts which brought about cultural changes within the group.

CHAPTER II : MATERIALS AND METHODS :

*** Area Of Study**

*** Methods**

*** Limitations**

*** Tools And Techniques Used**

MATERIALS AND METHOD

The village Lakhimpukhuri-Jai-Khan-Dang Gaon selected for the purpose of our study was none other than the one in which I grew up. As a participant in the various activities of the village and as a villager, I knew most of the people as my kins, as classificatory brothers, sisters, uncles and unts, etc. I was acquainted with the various activities of the villagers, the rituals and festivals and also the tussles, concerns and anxieties of the villagers. My training in Anthropology brought in a new consciousness in me. I could reflect on various beliefs and practices and think about their origin and functions. It was not possible to throw away my Ahom garb completely but I tried my best to step out of it and indulge in 'detached thinking' as much as possible.

The fieldwork for the study under question was carried out in five phases. The first pilot survey and household census were conducted in Oct-Nov. 1991. The first phase of the field data collection was done in Dec-Feb. 1991-92. The second phase of fieldwork was carried out in Dec-Feb. 1992-93. The final phase of it was carried out in Oct-Nov. 1993 and the data were cross-checked in Dec-Feb. 1993-94.

Area of Study :

The present study was conducted in the village Lakhimpukhuri-Jai-Kham-Dang Gaon which falls under Nazira sub-division of district Sibsagar. The village had its own historical significance (see chapter III). For the purpose of our 'acculturation study', this village fulfilled our objectives in three ways :

1. It was a single large Tai-Ahom village with 15 distinct local groups, i.e., "any aggregate of people, who inhabit a single, clearly demarcated locality and who regard themselves and act as a unit in relation to other local groups - may be sub-divided, and these sub-divisions are best referred to as wards" (Seligman 1960:64). These two local groups were divided into two separate units because of their adherence to different sub-sects of Neo-Vaisnavism. For the purpose of our study we presented these two units as *khels*.
2. Each local group was constituted by different descent groups migrated in from various places after the Mayamariya rebellion in 1780 forming an effective 'localized lineage'.
3. The historical forces operated in the past were common to all the Ahoms. Therefore that we selected a single village to examine those forces.

The village had, in the past, experienced two wars which affected its demographic constitution. First, it was the Mughal General Mirjumla's assault on the Ahom capital at Garhgaon, which plundered the village and secondly the Mayamariya rebellion which massacred its population. In both the instances the original inhabitants of the village established by the Ahom king had to flee out of the village.

The present day inhabitants of the village were believed to be the descendants of those members of the *khels* which were re-established during village reorganization programme under the directive of the Ahom monarch, and also a few other households which had migrated in from other villages for various reasons.

Methods :

The present study was based on ethnohistorical method (Herskovits 1962:171), which gained importance in anthropological research for documenting ethnographic and historical materials. The method involved reconstruction of a culture by collecting historical facts on the past contacts between historical peoples. The conditions antecedent to the contact were thus discovered, the pre-contact cultures of the peoples party to it was ascertained, and the present condition of the cultures was reviewed through ethnographic data (ibid).

Limitation of the method :

"Ethnohistoric data" included several classes. Class I of ethnohistoric data included direct records of law suit, land and tax registers, court proceedings etc. They were almost entirely etc. Class II of ethnohistoric data included descriptions of native practices

by foreign conquerors whose reports commingle in unknown proportions, eye-witness observation with informants' statements related to contemporary political, administrative, taxation and military affairs. Such data involved inconsistencies as they contained the accounts of informants who may be grounded in the ideological system of their own cultures. Therefore one required some valid techniques for sorting out such emic data from the etic. Finally, class III ethnohistoric data comprised of peoples' own records of history, reduced to writing either by themselves or by conquerors. Considering the possibility of exaggeration of such accounts or events, they were the least reliable evidence.

These few short-comings which appeared in ethnohistoric data were, by and large, taken care of by intensive field work with close observation of contemporary events and through direct interviews as well as by cross-examining the information through random interviews. Data pertaining to the oral history, myths and legends were also collected and rechecked.

Tools and Technique used in collection of data :

A. Household census :

Total household census were collected from each and every household of the village to get demographic account of its population.

B. Genealogies :

Extensive genealogies were drawn from the members of each and every household as far as the ego was able to recollect. The following information were collected from all the informants :

- a). Date and place at which record was taken.
- b). Name and social/religious group affiliation.
- c). Sex
- d). Age
- e). Birth-place : In case of those whose parents or grand-parents had permanently migrated from one village to another, the original village name is recorded.
- f). Marriage : Information regarding selection of mates so as to find out instances of inter-*khel* and inter-caste marriage etc were recorded from the genealogies.
- g). Kinship : Kinship terminologies and associated behaviour were recorded with the help of genealogies.
- h). Occupation

Following information were collected with the help of direct interviews through a schedule :

- 1). Commensal relations :
 - a. Location of the family hearth.
 - b. Food : taboo/restriction/rejection/acceptance
 - c. Initiation of family cook.
 - d. Concept of *chua* and *zutha*.
- 2). rites-de-passage :
 - a. Birth rituals
 - b. Puberty rituals
 - c. Marriage rituals
 - d. Death rituals
- 3). Village Community life through -
 - a. Festivals
 - b. Institutionalized corporate help :

Namghar and Haori.

CHAPTER III : THE AHOMS : A HISTORICAL PERSPECTIVE

- A) Hindu Cults, Sects and Sub-sects and Emergence of the Mahapurusia-Dharma and the Ahoms :
 - * Saivism
 - * Saktism
 - * Vaisnavism
 - Neo-Vaisnavism :
 - * Purusa-Samhati
 - * Nika-Samhati
 - * Kala-Samhati
 - * Brahma-Samhati
 - Neo-Vaisnavism And The Ahoms
- B) Social Organization Of The Ahoms :
 - * Family & Kinship

THE AHOMS : A HISTORICAL PERSPECTIVE- A

The following chapter presents a very brief account of the religious practices of the various communities in mediaeval Assam in general and those of the Ahoms in particular.

A) The Hindu-cults, Sects, Sub-sects and the Emergence of Mahapurusia-dharma and the Ahoms :

Traces of popular Hindu cults could be seen within the religious practices of a number of groups in mediaeval Assam. The Chutiya tribe, a branch of the Bodo-group, who ruled in the easternmost tract of Assam (present district of Tinsukia) had their prominence at Sadiya since early thirteenth century till their subjugation by the Ahoms in the early part of the sixteenth century. They propitiated various forms of the Goddess *Kali* with the aid of their priests called the *Deories*. *Kecaikhati* (the eater of raw flesh) was the most important form of *Kali* that needed to be appeased with human sacrifice (Gait 1984:42).

The Ahoms, a Shan group, had their kingdom to the west of the Chutiyas, worshipped their gods *Comdeo*, *Phra*, *Tera* and *Lengdon* etc., since their appearance in Assam in the fourteenth century (Gait 1984:74f.).

The Kacharis, a Tibeto-burman speaking group, had their kingdom to the south-west of the river

Brahmaputra river and followed at that period of time, their own religion until towards the closing decades of the sixteenth century when their kings formally accepted the Hindu-cult (Gait 1964:250).

A number of independent petty chiefs known as *Bhuyas* who ruled to the west of both the Kachari kingdom and the Chutiyas, were mostly *Saktas*. They included both the Brahmin *Bhuyas* and non-Brahmins including *Kayasthas* and *Kalitas*. The Koches, who ruled most of the western part of Assam, followed their own traditional religion till they were finally converted to Hindus (Sarma 1966:3).

Thus Assam in the fifteenth century presented a picture of distinct religious and linguistic groups, the majority of whom were non-Aryan. And those who professed Hinduism loosely adhered to *Vaisnavism* or *Saivism* and *Saktism* or *Tantricism*.

Saivism :

The worship of Siva in various forms was prevalent in ancient Assam. He was the tutelary God of ancient kings of Kamarupa from the seventh to the twelfth centuries (Sarma 1966:3). The various forms that were worshiped during

that period were viz., *Bhogi-Siva*, who was worshiped according to Tantric rites and *Yogi-Siva*, worshiped according to Puranic rites.

According to K.L Barua, the later kings of the Brahmapala dynasty were votaries of Tantricism. *Ardhanarisvara* - worship according to Tantric rite, was probably introduced by them. The king Dharmapala himself in his inscription salutes *Ardhayavatisvara* (K.L Barua 1936, cited in Sarma 1966:4). The Saivic Kacharis worshiped *Bathau-Brai*, a form of Siva by sacrifice of buffaloes, he-goats, pigeons, ducks and cocks and by offering of rice and liquor. Naranarayana (1540-1584), the Koch king was stated to have legalized this form of worship of Siva by the issue of an edict which set apart the north bank of Brahmaputra for the practice of aboriginal forms of worship (B.Kakati 1948, cited in Sarma 1966:4).

Saktism :

Sakti, in her various forms, was a dominant cult of Assam in ancient and mediaeval times up to the advent of Neo-Vaisnavism, and even today, it holds a place next to Vaisnavism. The main centres of Saktism were the shrines of Kamakhya and Dikkaravasini. According to Kakati (1948:35-70) Dikkaravasini could be equated with the Goddess

Tamresvari or Kecaikhati to whom human sacrifice was offered. Human sacrifice was also performed in the Jayantesvari temple of Jayantiyapura.

The Snake-Goddess *Manasa*, a manifestation of Sakti in Assamese kavyas, the *Padma-purana*, and the *Beula-upakhyana* composed by Mankar and Durgabara during the last decades of the fifteenth century, was very popular in western parts of Assam.

Vaisnavism :

The worship of Visnu in the form of Vasudeva in ancient Assam was quite evident from the Baraganga inscriptions of Mahabhuti Varman (554 A.D) which referred to the king as *Parama-Bhagavata*. The *Kalika-Purana* (c.12th) mentioned five manifestations of *Vasudeva* with their *pithas*, of which *Hayagriva-Madhava* at *Manikuta* and *Vasudeva* in the *Dikkaravasini* region were most important (Kakati 1948:71-72). King Laksminarayana who ruled at *Sadhayapuri* recorded in his inscriptions (1401 A.D) that he granted two hundred *putis* of land in the village *Bakhana* to a Brahmin *Ravideva*, son of *Harideva*, who was a regular worshiper of *Vasudeva* (*The Journal of the Assam Research Society* vol.III, No.2:42).

However, there was a considerable predominance of Saivic and Sakti cults over Vaisnavism. This was because, "...majority of the Hindus instead of delving

deep into the mysteries of Tantricism of Sakti and Saiva cults, resorted to them and adopted the outward philosophy of sex and palate as the real criterion of their religion" (Sarma 1966:6). As Kakati put it:

The land was infested with itinerant teacher with the Vamacara Tantric schools with their insistence on the philosophy of sex and palate. Among religious rites, the most spectacular were bloody sacrifices to gods and goddesses amidst deafening noises of drums, cymbals, night vigils, virgin worship and the lewd dances of temple women (Kakati 1948, cited in Sarma 1966:6).

Emergence of Mahapurusha-dharma : The Neo-Vaisnavism

Towards the closing decades of the fifteenth century, the religious history of Assam took a new turn. It was Sankaradeva who initiated the Neo-vaisnavite movement and firmly established the vaisnava faith as the supreme religious order in the Brahmaputra valley. His ideal was to propagate a simple system of religion based on devotion and faith. He was not interested on a philosophy of religion, for he knew that the society was more in need of a reformation than a system of philosophy. And thus *Bhakti* became the most important aspect of his religion. The essence of *Bhakti* was mainly derived from *Bhagavata-purana* and *the Gita*. This was quite evident from their works like -1. *Bhakti-ratnakara* and *Bhakti-pradipa* by Sankaradeva, 2. *Bhakti-ratnavali*, an Assamese translation by Madhavadeva, 3. *Namaghosa* by Madhavadeva, 4. *Bhakti-viveka* by Bhattadeva and 5. *Ghosa-ratna* by Gopala Misra; all written in the sixteenth and the early part of the seventeenth centuries. The new cult thus

moulded according to the local circumstances, was popularly known as the *Mahapurusia-dharma* or *Ekasaranadharmā* or the religion of supreme surrender to one God, i.e., *Visnu* or *Krisna*.

After the death of Sankaradeva (1449-1568), when Madhavadeva succeeded him, there was a general discontentment among some senior disciples of Sankaradeva. A section of the Vaisnavas headed by Damodaradeva seceded disowning Madhavadeva's leadership.

When Madhavadeva died, he did not select anybody to be his successor. The disciples found themselves under the leadership of Gopala Ata, Purusottama Thakur and Mathuradasa respectively. This gave rise to three sub-sects along with the one which was earlier founded by Damodaradeva and Harideva. These sub-sects came to be known as *Samhatis* meaning associations. Thus there were, *Purusa-samhati*, *Nika-samhati*, *Kala-samhati* and *Brahma-samhati*.

Purusa-samhati :

This sub-sect was founded by Purusottama Thakur after the death of Madhavadeva. This samhati laid special emphasis on *Nama* which was one of the four fundamental

elements in the practice of devotion. Chanting and singing in praise of God and meditating on his various forms and names were considered acts of special merit according to this sub-sect. The followers of this sub-sect observed Brahminical rites and might worship the image of *Visnu*. The position of Sankaradeva was unique in the hierarchy of religious *Gurus*.

Nika-samhati :

This sub-sect was engineered by Padma Ata, Mathuradasa and Kesava Ata with a view to purify the vaisnava sect by laying stringent rules and conduct of life. The name *Nika* stood for pure or clean and the followers of this sub-sect were required to observe strict discipline in respect of food, dress and manners and in all religious matters. It laid special emphasis on serving holy association (*Sat-sanga*). It denounced idol-worship and placed Madhavadeva on the highest rung of the religious hierarchy.

Kala-Samhati :

This association owed its origin to Gopala Ata. This sub-sect gave the supreme position to its Guru. To the followers, the Guru was the God in human form. The followers of this sub-sect were known as *Matak*. Majority of the disciples were Ahoms, Chutiyas, and 'Doms'. The influence of Brahminical rituals was reduced to a negligible position.

It was this *Samhati* which was primarily responsible for bringing to the fold of Vaisnavism the tribals and socially backward communities. The practice of initiating woman was absent in this sub-sect.

Brahma-samhati :

This sect was founded by Damodaradeva and Harideva. It was a Brahminical swing-back to orthodoxy that impelled Damodaradeva to disown his association with the original sect of Sankaradeva and Madhavadeva. Most of the *Satras* affiliated to this *samhati* were headed by Brahmans. The leaders of the *Brahma-samhati* showed that the *Vedic* and *Puranic* rituals and devotional practices were not mutually exclusive. One could be a good *Vaisnava* even performing daily and occasional rites enjoined by the *Dharmasastras*. This nature of the sub-sect helped considerably to include the twice-born classes to its fold. It laid more emphasis on *Deva*, the God and hence approved worship of *Visnu* image.

Neo-vaisnavism and the Ahoms :

Throughout the history of the Ahom monarchs, they never had a consistent religious policy. And accordingly, religious activities were determined more by the temperament of the kings and as to which sect or cult they patronized. Therefore, like any other popular Hindu-cults in Assam, Neo-Vaisnavism too had a chequered history of its own.

In the initial stage, *Mahapurusia-dharma* could not gain patronage of the State and Sankaradeva with his followers had to move out to the Koch kingdom around the middle of the sixteenth century A.D. The pioneer reformer like Vamsigopaladeva had to live in hiding for several years when his *satra* at Kalabari was set on fire under the orders of *Burha-Raja* Pratapa Simha. The two colleagues of Gopaladeva, Mukunda Gosain and Balabhadra were beheaded. The Kuruwabahi *satra* was demolished. All these happened "at the instigation of the interested Brahmins" (Gait 1964:p-121).

Later the fourth *Adhikara* Nityananadadeva of the Mayamara *satra* was put to death by Surampha's order (1641-1644). The three sons of Bar-Yadumani of Bahbari *satra* were tortured and killed by the king *Nariya-Raja*. Jayadhvaja Simha (1648-1663), who was a disciple of *Brahma-samhati*, persecuted and killed the leading members of the *Mahapurusiya* sub-sect.

When Gadadhara Simha became the king in 1881, he confiscated the properties of *satras* and idols of deities were either melted down or thrown away. The *Adhikara* and *Gosains* of the Dakhinpat *satra* were blinded, while the *Adhikara* of the Auniati *satra* was exiled to Sadiya. Such persecutions were carried out since the king considered the

satras as States within the State and as such might pose a threat to the sovereignty of the State. Moreover, when Gadadhara Simha was wandering from place to place to escape persecution by the then king, he was maltreated by some of the members of the Dakhinpat *satra*, an incident which later invoked revenge against the *satra*.

When Rudra Simha came to power (1696), he showed a conciliatory spirit in his attitude towards the *Vaisnavite* sects. He recalled and reinstated the exiled *Gosains*. But under the influence of Brahmans, he developed certain prejudices against the non-Brahman *Gosains*. They were forbidden to initiate or ordain Brahmans. Never-the-less, he maintained such a policy towards the *Vaisnava*-sects which gave official recognition to a number of *satras*.

But then, Siva Simha son of Rudra Simha, who was a disciple of a *sakta* Brahman of Bengal along with his queen Phulesvari, a fanatic *sakta*, assumed vindictive attitude towards the *Thakuria-vaisnavas* which later resulted in to the Moamariya rebellion that erupted from time to time. In short, such apathy for the *Vaisnavas* were seen mostly during the reign of Siva Simha, Rajesvara Simha and Laksmi Simha who were all *saktas*.

However, towards the later part of the Ahom rule the State's attitude towards *vaisnavas* started changing. From Jayadhvaja Simha (1649-1663) till Ratnadhvaja Simha (1679-1681 A.D), the monarchs and the nobles became disciples of the *vaisnava Gosains*. A number of important *satras* of the eastern Assam were established under the royal patronage. Even an officer, *Satriya-Barua*, was appointed to look after the workings and management of the *satras* and to advise and remind the new *Adhikara* of the duties towards the king and the State.

Later, a new custom in the form of blessing the king by the heads of the principal *satras* on the occasion of the coronation ceremony came into vogue. Accordingly, the king Pramata Simha (1744-1751), Rajesvara Simha (1751-1769) and Gaurinath Simha (1780-1794) succeeded to the throne. Thus by then, *Neo-vaisnavism* which hitherto had to face persecutions by the State became the most powerful religious institution under the royal patronage.

THE AHOMS : A HISTORICAL PERSPECTIVE - B

This part of the chapter presents a historical account of the Ahom social organization.

B) Social Organization Of The Ahoms :

The Ahoms, a Mao-shan branch of the Tai race of southeast Asia, came to Assam through the Patkai hills of upper Burma (Gogoi 1968 : 252). Their traditional social organization was based on nuclear families concentrated into village cells. The concept of state, i.e. *Muong* centered around a leader in whom the military and the civil functions were equally combined. (Buragohain 1988:34) They were basically valley dwellers and had their expertise in wet rice cultivation.

Their traditional social system was known as *Ban-muong* and it was related to agriculture and based on irrigation by drawing water from the brooks and rivulets by means of constructing dams and dykes. A brief analysis of this system can be made as follows:

The *Ban* was essentially a unit of social organization. The *Ban* or *Ban Na* was composed of nuclear families that settled by the side of brooks or rivulets. A number of such *Ban Na* together formed a *muong*. The *muong* thus

formed was an inter-*Ban* organization based on hydraulic culture that extended over a large area of agricultural lands.

The *muong* was headed by a leader who controlled and managed the water resources for the purpose of agriculture. He was considered to be the soul of the earth and water. Therefore, he assumed a deified personality, being solely responsible for the distribution and conservation of the water resources. Such a responsibility often required strong hands to curb down any conflicts that might occur while re-establishing the *Ban* or *muong*. The leader thus needed to assume military power as an when necessary. Thus there was gradual development of power from the management of water resources to the management of internal affairs and the subsequent formation of the real *muong* i.e., the state (Tran-Quoc-Vuong 1984).

The role of myths in the formation of traditional Ahom society could not be ignored. And as such the Ahom kings, throughout their six hundred years of rule, claimed descent from their heavenly ancestor *Lengdon*, the supreme ruler of heaven. The chronicles of the Ahoms, exclusively mentioned the directive of *Lengdon* which substantially pointed to the Ahom polity. Some of such directives, were :

'...there is no ruler on earth, I think, the wife of one is forcibly taken by another ...Large fields are lying fallow. These may be well cultivated'.

'...You should try to get the hearts of the people with sweet words ... You must always be alert in carrying out state's affairs'.

'...The countries are not properly ruled. The strong oppresses the weak. They live on cultivation ... You must rule the *vide* countries peacefully. You will take tributes from the people,...Both of you must rule the countries without quarrel,...'.

'...if you quarrel amongst yourself, you are sure to lose your royal power'.

'... the country is full of Tais and slaves. They can not distinguish right from wrong'.

'...if a person commits a crime, do not kill him at once without fair trial ...If any of them lives by oppressing others , he should be sent to exile..' (Buragohain 1988 : 47).

Guha thus observed that -

"The Ahoms thus believed that they were divinely ordained, firstly, to extend their permanent wet rice culture to areas dominated by large scale fallowing and shifting cultivation, and secondly, to absorb stateless shifting cultivators in to a common polity (Guha 1967:n.28:14, cited in Buragohain 1988 : 48).

The Ahoms within their *muong* with their king as the leader were divided into numerous divisions, some of which had formerly ascribed ranks and maintained a sort of hereditary aristocracy, while the others were purely functional. Besides the aristocracy, the commoners were mainly divided into :

1. *The Chamuas* or the gentry.
2. *The Kheluwas* or the functional sections.
3. *The Meldagiyas* or the sections assigned to various members of the royal family to serve as attendants.

The Ahoms were traditionally said to have come with seven clans or the Ahoms of seven houses (*The Satghariya Ahom*), of which three clans were royal. From the first clan came the kings, the other two were of the ministerial clans. The *Buragohain* being the senior minister and the *Borgohain*, junior to him. The last three clans were the priestly lineages, the *Deodhai*, *Mohan*, *Bailung* and *Chiring*.

The king was the supreme head of the state. The post which was hereditary to one of the following lineages : *Dihingiya*, *Charingiya*, *Tungkhungiya*, *Namrupiya*, *Samaguriya*, *Tipamiya*, and *Parvatiya*. The *Buragohain* and the *Borgohain* were placed next to the king. The king ruled the *muong* on the advice of his council of ministers. These lineages were formed as and when the Ahoms left behind a garrison of their own clan members at a number of places that their leader had stayed prior to the establishment of a sedentary life, and as such all these names actually denoted the names of those places.

Later the expansionist attitude of the Ahom king brought under them a large territory which demanded the creation of new administrative posts and thus a new post of *Barpatra Gohain* (Minister-courtier) was created during the

reign of *Cu-Hum-Mong* (1497-1538). The king Pratap Simha created two new posts of *Borbarua* and *Borphukan* being the Secretary General and Governor General. Most of the *Borbaruas* were selected from the Morans, Kachari, Chiring and Khamti families. The office of the Governor general, lower Assam was appointed from a Chutiya family. These offices were not hereditary and thus could be selected from any families except from the two original ministerial clans.

Many a group from the neighbouring areas were also inducted into a number of important offices. For instance, the Miri Sandikai and the Maran Patar were the officers drawn from the Miris and the Marans. Similarly a number of oracles were included into the *Bailung* group. Thus there were the Naga Bailung, Miri Bailung and Nara Bailung.

The first Ahom king, after the subjugation of the Barahis, married a Barahi princess when he discovered that the food cooked by her was extremely delicious and thus created a new clan called *Changmai*, the royal cook, drawn from the Barahi tribe. The descendants of this clan were engaged in various functions associated to the royal kitchen and accordingly eight sub-groups were formed to cater to the need of the kitchen. For example, the groups like the *Kathkotia*

(fire-wood supplier), *Randhani* (cook), *Kharbatiya* (one who prepares a special kind of vegetable soda) etc., came into being.

The commoners were organized in the form of *paik* or the *khel* system. An adult male was called a *paik*, and four *paiks* constituted a *got*. The *gots* were further attached to *khels* and depending on the nature of duties, the strength of each *khel* varied from one to three thousand *paiks*. Each *khel* was in charge of officers with varying ranks. Twenty *paiks* were commanded by a *Bora*, one hundred by a *Saikia*, one thousand by a *Hazarika*, three thousand by a *Rajkhowa*, and six thousand by a *Phukan* (Gait 1904 : 249). These posts were filled up by any able persons from any families.

Traditionally the Ahoms were an endogamous group following clan exogamy. The *Satgharia Ahoms* were more rigid in this regard. The practice of maintaining *banshawali* (genealogies) helped them to avoid unprescribed marriage. The kings and the nobles, however, accepted their consorts even from the common stock (Barua 1978:22). As a rule marriages were restricted between *Buragohain* and *Buragohain*, *Borgohain* and *Borgohain*, *Borpatragohain* and *Borpatragohain*; and within the same *khel* between *Chetia* and *Chetia*, *Mohan* and *Mohan*,

Bailung and Bailung, etc. In the case of any breach of such marriage rules, a person was stripped off his clan status and excommunicated. Adultery was dealt with strong hands. Such persons were socially boycotted and forced to live in separate villages specially established for them; and were labelled as *Gorias*. Among the gentry, the Koch, Kachari, Chutiya, Ahom, Maran and Barahi, married freely among themselves. The affluent Ahoms who enjoyed special status within the state according to their birth looked for Ahom boys for their daughters but their sons could marry from any of the aforesaid groups.

Prior to their migration to Assam they were followers of Tao religion. *Tao* or *Teh* means unlimited, unending or the entire cosmos. This *Tao* in *Taoism* was the *Fra-tra* or *Fura-tera* the supreme super natural power of the Ahoms. When they came to Assam they were followers of a religion which appeared to be a mixture of Taoism and Buddhism in somewhat diluted form and upon which a tinge of tantric Buddhism and Hinduism could be seen. Prior to the advent of Neo-vaisnavism, the Ahom readily accepted the prevalent religion of the land. This was quite evident from the history that they appeased *Kecaikhati* the Chutiya Goddess in Sadiya, worshiped *Caraideo* in *Caraideo* and sacrificed animals in

Ram-kha and Devar Gaon *Deo-shal* (Altar). By then the other groups like the Chutiya, Kachari and Maran etc., all of whom also had migrated from southeast Asia, had imbibed Hinduism to some extent. The Ahoms who later came to Assam, and started living with these autochthons perhaps became attracted to Hinduism (Gogoi 1985:23). However, the Ahoms took four hundred years to be recognized as Hindus and it was during the reign of Rudra Simha (1696) that Hinduism became a state religion.

The Ahoms were outside the purview of the caste system. Citizens from all caste and creed were treated equally. Only the royal families along with the ministerial families held a special status according to their birth in the respective clans. Other officers of the royal court enjoyed a social status according to their official ranks. Later, when Hinduism became the state religion, the gentry were divided into a number of classes like the Brahman, Kayastha, Kalita, Keot, Koch and Kachari, etc.

The Ahoms had a strong administrative policy; rewards and punishments were equally meted out as and when required. Only the Brahmins and women were free from capital punishment. Even the Gosains and Mahantas were punished in the case of any breach of social norms. Officers

of higher ranks were also not spared from such treatment. The king, Buragohain, Borgohain, Borpatragohain and Borphukan could declare capital punishment. Higher officers could also hear and settle disputes among the *paiks* and award punishment of lesser degree. However, the persons so punished by these officers could appeal to the king for a better hearing.

kinship :

The Ahom commoners were divided into different *phaids* or *khels* on the basis of their specific, assigned occupation and their hereditary status. Thus in a traditional Ahom society, the hereditary aristocracy (*Sat-gharia* Ahom) on the one hand and specific occupation on the other, helped in the growth of Ahom social organization in terms of *phaid*. The hereditary aristocracy was maintained with the practice of writing *Banshavali*, i.e., genealogy and the occupational status of the *phaid* was assigned by the royal court. Each *phaid* was again divided into sub-*phaids*.

Endogamy to a large extent was maintained by restricting their marriage within the Ahom community. It was a strong patriarchal society and the people traced their descent through males to a common ancestry. Marriage was not permitted, not only within the same *phaid*, but also among the other sub-*phaids* of the same *phaid*. The exogamous nature of

phaids, as Barua (1978:104) said, could be compared to some extent with the clan and lineage group. The members of each *phaid* were widely dispersed throughout upper Assam. Nevertheless, membership to a specific *phaid* signified that they were the descendants of a common ancestor.

Members of the sub-*phaids* were equally affected by ritual pollution whenever occasion arose. But it was not possible to maintain functional integrity due to spatial dispersal of kinsmen (Barua 1978:109).

Kinship system of the Ahoms was distinctive as it followed seniority on the basis of ascending generations rather than on age. In course of their long contact with other autochthons in Assam, there had been partial changes in the kinship terms; nevertheless, certain terms like *Nisadeo*, *Epadeo*, *enaideo*, *Puthadeo*, *Athao*, *Pulin*, *Aputi*, etc., were retained. For instance :

| <u>Terms Of Reference</u> | <u>Relations</u> |
|---------------------------|-----------------------------|
| <i>Nisadeo</i> | MoBr(☉)/FaBr(☉) |
| <i>Epadeo</i> | MoBrWi/FaBrWi/MoZ(☉)/FaZ(☉) |
| <i>Enaideo</i> | MoMo |
| <i>Puthao</i> | MoFa/FaFa |
| <i>Athao</i> | FaMo |

CHAPTER IV:

THE AHOMS TODAY : I

- A) History Of The village
- B) Social Relations Through Commensal Relations :
 - * Location Of The Family Hearth
 - * 'Majia'
 - * Initiation Of The Family Cook
 - * 'Jui-Hal'
 - * Food:Acceptance/Rejection/Restriction and Taboo
- B) Social Relations Through Beliefs And Practices.
 - Rituals Related To Birth :
 - * Conception
 - * Child Birth
 - * Cutting Of Umbilical Cord
 - * Dispersal Of After-Birth
 - * Drying Up Of Abdomen
 - * 'Jaal-Diya'
 - * Introducing The Child To The World
 - * Name Giving Ceremony
 - * 'Hudi' or 'Annaprasana'
 - * First Hair Shaving
 - Rituals Related To Adulthood:
 - * 'Nua-Tuloni-Biya'
 - Marriage Ceremony :
 - * 'Tamul-Pelaboloi-Zua'
 - * 'Pani-tula'
 - * 'Jurun'
 - * Chak-Lang
 - Marriage By Elopement :
 - * 'Sur-Dhara'

MAP OF LAKHIMPUKHURI-JAI-KHAM-DANG VILLAGE

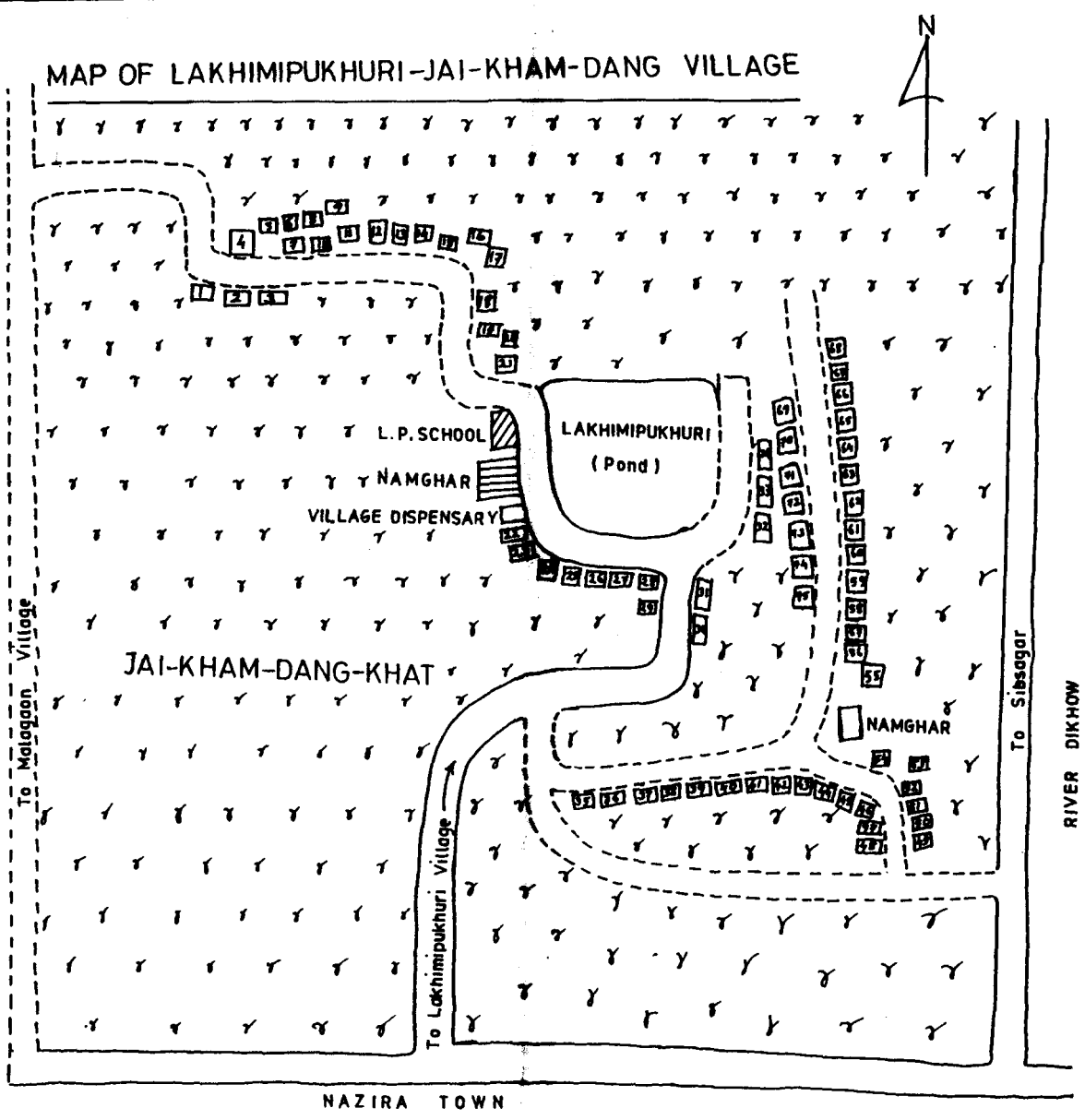

- Household No. 1-34=Khel-A
- No. 35-75=Khel-B
- No. 1-21=Da-Cuk
- No. 22-34=Pukhuri-Cuk
- No. 35-75=Tairui-Cuk

- METAL ROAD
- UNMETAL ROAD
- AGRICULTURAL LAND
- HOUSE

Not to Scale.

THE AHOMS TODAY : I

The following chapter deals with the contemporary situation of the Ahoms in a village. Here we are presenting an ethnographic account of the people of Lakhimpujhuri village in terms of their social relations, kinship and beliefs and practices.

A) History Of The Village :

The village Lakhimpukhuri-Jai-Kham-Dang Gaon is in itself an important name in the history of the Ahoms. During the reign of the Ahoms, a number of *khats* were established for wet-rice cultivation. *Khat*, in Assamese means a well demarcated agricultural land. Among all the established *khats*, The **Jai-Kham-Dang**, established by the Ahom king Chuceng-Pha alias Pratap Simha (1606-1642 AD) was the largest and had much historical importance. It falls in the district of Sibsagar under Nazira sub-division. It is in the north-west side of Nazira town.

The etymology of the words **Jai-Kham-Dang-Khat** is a pan derived from three different words. The associated folk tale is equally interesting and humorous too. The pan is drawn from **Jai** meaning name of a person, **Kham** means gold, and **Dang** stands for a long lever especially of bamboo, and is used to carry load. Soon after Pratap Simha's installation as the king, he planned for a

political, social, cultural and economic development of his people. The *khat* was an outcome of his developmental plan. It was said that a large plot of land belonged to a person named Jai who did not have any issue. The king ordered Jai to leave his land and the place, for he wanted the land to be converted into a *khat*. Since the land was his ancestral property, Jai refused to do so. He was summoned to the royal court. Even in the court, Jai was reluctant to give away his land. The king then assured that he would give any value that Jai could ask for his land. On hearing the king, Jai hesitantly placed his wishful price for his land. He said, if the king could pay him in gold as much as his person's weight, he would leave his land. The king agreed upon the deal and Jai was weighed against gold. Jai then packed his *Kham* (Gold) in a big piece of cloth and used a *Dang* (A bamboo lever) to carry his gold out of his land. Since then the *khat* came to be known as *Jai-Kham-Dang khat*.

According to another legend, the words *Jai-Kham-Dang* were derived from the words *Jai* meaning elevated land, or hillock; *Kham* means gold, cloth, or granary etc., and *Dang* means a bamboo lever. It may be said to mean a *khat* which was established by leveling hillocks and from where the golden harvest was carried to the granaries on a lever. And that was how the name *Jai-Kham-Dang* emerged.

Besides these interesting etymologies of the *khat*, it has many more gifted advantages for wet-rice cultivation. In the north-east of the *khat* flows the river Dikhow, and to the south-west flow the rivulets Naphuk and Dimow. It is believed that the harvest from this *khat* is of relatively high variety and tastes better. It is evident from the following lines drawn from the folk culture :

" Engerer goru, Pengerer caru;
Balamar mas, Jai-Kham-Dangar bhat".

Meaning that the bulls from Engera, earthen vessels from Pengera, fishes from Balama, and rice from Jai-Kham-Dang are invariably of the best variety that one could get in the region. On the east of the *khat* fall Na-Mati village, and the river Dikhow. On the west fall Kapahuwa and Rewati village. Towards north lies Mathiasinga Dihingia village and to the south falls the Nazira town.

The entire *khat* (4000 *bighas*) was embanked on four sides with elevated earth fillings, locally known as *garh*. There were four three-sided stone posts implanted one in each corner. Only one such post still stands some three feet above the ground. Most of the embankments are now slowly being leveled into agricultural land. The *khat* was divided into four equal parts by two more lines of earth fillings, one crossing the other in the middle of the *khat*. These were

used as roads in the past and are known as *bokia*. In one of these four plots, the one in the north eastern side, there existed a royal garden called *Rajabari* established during the reign of Chuk-leng-mung alias Gorgoya Raja in 1552 AD, long before the *khat* came in to being. This garden was also demarcated by embankments on four sides which are now mostly converted into cultivatable land. From the governmental record the garden spreads over 50 *bighas* of land.

It is said that there were twenty four royal granaries in this garden. All the royal produce from the *khat* were stored in these granaries. According to Sir Edward Gait (1964:134) during the reign of Jayaddhvaj Simha, the Mughal General Mirjumla, after conquering the Ahom capital at Garhgaon, took away with him 82 elephants, 3 lakh rupees worth of gold and silver and grains from 170 granaries. It is believed that out of 170 granaries that were looted 24 granaries were from *Rajabari*.

The Moamaria rebellion which started during the time of king Rajesvar Simha (1673) could not do any harm to the state at the initial period. Later in 1691 to 1795, when king Laksmi Simha and Gaurinath Simha were respectively on the throne, the rebellion took a serious turn. In 1780 (on 2nd *Vaishak*) the Moamarias went berserk and destroyed besides

houses, a number of granaries. It is believed that it was at that point in history when all the 24 granaries of Rajabari were burnt to ashes. Even today people believe that if one digs about 1 to 1.5 feet deep, one can still see the remnants of the burnt paddy husks.

There were two ponds in Rajabari which have now become shallow and marshy. Much of them are now filled up and extended to the cultivatable land. They are now beyond any renovation. We do not have the original names of these ponds, but today they are locally known as *Nangal-dhua-pukhuri* (where the farmers were said to have washed their ploughs), and *Kur-dhua-pukhuri* (where spades were washed).

Within the Jai-Kham-Dang *khat*, between the north west part of the *khat*, lies a large tank known as *Lakhimi-Pukhuri*. It is after this tank that the village bears the name *Lakhimipukhuri-Jai-Kham-Dang* gaon. According to Lila Gogoi (1985) the tank was dug out during the reign of king Jayadhwaj Simha (1646-1663 AD). The government's records shows that the tank covers around 20 *bighas* of land. Today, although the tank remains full but its water is not safe for domestic use. The village folks, cattle and other domestic animals freely wade through its water.

The village settlement :

A total of 75 households with a population of 468 are distributed in three major pockets or *cuk* which constitute the village settlement. On the north bank of the tank lies the *Dā-cuk* (pocket-I) with a total of 21 households; on the bank of the tank, i.e., *Pukhuri-cuk* (pocket-II) which spreads from north east towards south west, reside 13 households. All these 34 households, although belong to a number of independent descent groups, together form the *khel-A*, and they believe in *Brahma-samhati* sect affiliated to Dakhinpat Satra. The remaining 41 households are distributed in and around Rajabari which is known as *Tairai-cuk* (pocket-III). They constitute the *khel-B*, and belong to the *Kala-samhati* sect of Neo-vaishnavism affiliated to Bareghar Satra.

If we present the total number of households in to a number of descent groups with their strength in a descending order, then we find that :

In *khel-A/pocket-I (Dā-cuk)*

Group-I has 10 households with 66 living members (men, women & children excluding those women who are married out);

Group-II has 5 households with 26 living members;

Group-III has 3 households and 28 living members;

Group-IV has 2 households and 12 living members;

Group-V has 1 household with 5 living members.

In *khel-A/pocket-II* (Fukhuri-cuk)

Group-I with 10 households and 52 living members;

Group-II has 1 household and 12 living members;

Group-III with 1 household and 4 living members; and

Group-IV also with 1 household and 4 living members.

In *khel-B/pocket-III* (Tairai-cuk)

Group-I has 16 households and 105 living members;

Group-II has 13 households and 87 living members;

Group-III with 4 households and 26 living members;

Group-IV has 4 households and 25 living members

Group-V with 3 households and 12 living members; and

Group-VI with 1 household and 4 living members.

The descent groups with the highest number of households and members in each pocket usually claim to be the oldest group in their respective pocket. Groups with lesser number of households and members in any pocket are so, by and large, owing of migration of their sblings to different places; and groups with the least number of households are formed either by a relatively recent emigrant family, locally known as *bhagania* (refugee) or by a person who

initially stays with any family as a helping hand in the fields, and who later starts living independently after having married to a daughter of that family. Such a person is known in the village as *sapania*. Incidence of both the kinds are seen in this village.

In spite of the fact that the village has a multiple number of independent descent groups, it represents a well knit coherent social unit within and without the *khel(s)*. Each such *khel* has its own *Namghar* (community prayer hall). In *khel-A*, the head of the *Namghar* is known as *Medhi*; and in *khel-B* he is known as *Sajtula* (see on *Namghar*).

The village can be approached through different motorable roads from the town; one through the central *bokia* that cuts the *khat* from south to north. It is black topped and passes through the pockets III and II, and finally by touching pocket-I it links the other road which was one of the erstwhile embankments. This is a *kuccha* road that runs on the western side of the village. The village has a primary school with a pre-primary section attached to it. There is also a primary health center manned by a nurse and an auxiliary nurse-cum-mid-wife. The village also has a small library run by two employees.

The primary source of earning is through agriculture, although there are other sources too, viz, teaching, government and semi-government employments, and labour on daily wage. The two *khels* within the village can be viewed as two distinct categories on the basis of the existing institutionalized dichotomy of the popular religion (see on Neo-vaisnavism). There has been a number of incidences of inter-*khel* marriages in the past and present generations. The social relations within the village are more or less independent of their differences in the religious orders.

B) Social Relations Through Commensal Relations

Food plays an important role in the society. It demarcates a boundary of the group by its acceptance and restrictions. Most of the social relations are intertwined with food. Its procurement, cooking and distribution must follow a pattern as prescribed by the culture and which is discussed as follows :

Location of the kitchen in relation to the household :

An Ahom house usually has four important compartments which have their own specific places in the total layout of the house. They are the main kitchen or the family hearth, locally known as *majia* which includes a subsidiary kitchen called *juihal*. In second comes the granary and then come the poultry and cow-shed. In relation to the main house, all these constructions are made in predetermined directions (fig.I, Appendix). Therefore, whenever someone plans to build a house in the village, we keep hearing the elders saying:

"...Pube bhadal, paschime gadal;
uttare caru, dakshine garu".

Meaning that in relation to the main house the granary should be placed in east; poultry in west; kitchen in north; and cow-shed in south. If one plans his house accordingly, he would have a perfect house.

The main thrust of such a plan may be seen in terms of a dyadic relationship of public and private. The granary facing the main entrance and the cow-shed by its side are the two important structures of public exhibitionism. The prestige and pride of the owner associated with the size and number of granaries that one has, and also the number of cattle that one possesses, are the reflective indices of one's wealth. On the other hand the kitchen and the poultry which do not come to the sight of a visitor are private part of the house. Moreover, the restriction of entry to the main kitchen also gives a private and sacred status to it.

There are many more associations of direction in the day to day life and which are also related to rites of passage (see on beliefs and practices). Similar association is also evident from the saying :

"...Uttare lor, dakshine khor..."

Meaning that if the rain bearing cloud gathers on the northern sky, one should rather not think twice but run for his safety, because a heavy shower with hail stones is definitely going to hit the ground at any moment. Or if the clouds gather on the southern sky one can only be *khor*, meaning - increase the pace of his steps so that he reaches home in time just in case it happens to rain.

Kitchen is the most important place of any household where the family hearth is placed. Ideally, the position of the hearth in relation to the house is in north. *Majia* is the main kitchen where the main meal is cooked. The place is considered to be the sacred and is governed by well established norms.

Majia or Ashahal :

Asha in Assamese means expectation; and *hal* means site or place, that is the place from where every one in the household, men, women, children and even animals, expect food to satisfy their hunger. This place is managed by the eldest lady (*Ghai-manuh* : main person) of the house. In absence of her, no one has the right to enter *majia*. Boys and girls before their onset of puberty are considered pure and may be employed to serve the cooked food to the other members of the household if in case the lady of the house is away during meal time. The male members of the house if initiated (see on concept of *chua*), may officiate the lady as and when required. This is mainly done when the main cook is away or she is ill or she is in her periods. In the last case, she is considered to be impure or *chua* for a period of three days. Sons when they get married, their wives may be initiated as family cooks. Ideally, men and women before they get married are taken to the *Satra* where they are formally initiated to the *Vaisnavite* fold and also as cook.

Initiation of the family cook :

Initiation of a cook is different from that of initiation to the *Vaisnavite* fold. A person may be initiated as a cook by a person who has already been initiated as a *Vaisnavite* disciple by a *guru* from any of the recognized *Satra*, and if he is the *medhi* of the village. An orthodox *Vaisnavite* would not accept even water from a person who has not been initiated as family cook (within the *khel*). In the present village Lakhimpukhuri, this particular ceremony can be seen in various forms.

In *khel-A*, which is more adherent to the *Brahma-Samhati* sect (see on Neo-Vaisnavism), initiation is usually performed at two different levels - at the family level, the elderly woman or the man of the house initiates the person. The process here is simple and follows in this manner :

After having the *preliminary bath* (Dumont 1988:140) the person to be initiated is lead to the kitchen where he/she is acquainted with the norms and regulations to be followed. The rules here are simple and they conform to a pan-Indian way of cooking (Dumont 1988:138) i.e., the person bathes before entering in to the kitchen and avoid contact with any polluting agents. This is because like any other

Hindu villages in India the observance of ritual purity is particularly focused on the kitchen (Mandelbaum 1970:197). Then the person is asked to utter the names of the stands on the hearth (usually five in number on a standard hearth. See fig.II/I&II) which are a ritual secret, name the grain to be cooked and name the water which is being used (a synonym). This is followed by a short prayer to *Hari* (Krisna) and showers of blessing from the initiator. Henceforth, anybody can accept food and water from this initiated person. The entire ceremony involves just two persons, the initiator and initiated.

The other way of initiation that is seen in this village is by inviting an odd number of *bhakats* (usually in three, five or seven elderly male members including the *medhi* of the village) to the house. The *bhakats* offer *prashad* (consecrated food) on a *xarai* (fig III/II) which is placed on a ritually purified space in a room and may recite a few verses from *Nam-ghosa* (devotional verses written by Madhavadeva). The ritual concludes when the initiated person bows down before the *bhakats* and the *medhi* blesses him.

In *khel-B*, the practice of initiating women is totally absent due to their allegiance with *Kala-samhati* sub-sect. According to this *samhati*, *Bhakti* can not be cultivated by owning double allegiance to the husband

as well as the *guru*. Therefore, initiation as family cook is not necessary within their sect.

Juihal (Jui=fire; hal=site or place) :

Juihal or the subsidiary kitchen usually precedes *majia* in the sense that one has to pass through *juihal* to enter *majia*. Here, there used to be a make-shift type of hearth (fig.II/III) in a corner on which a kettle with tea liquor in it is always there. This hearth can be managed by any one in the family except the menstruating women. The place is also used as a dining place and most of the visitors are served tea here. Besides, young men and women are often seen cooking their delicious dishes in *juihal* for their own consumption.

Food - acceptance/rejection/restriction, and taboo :

Food as Mandelbaum puts it - "...food and water are susceptible to ritual pollution and so each villager must take care about the purity of what he eats and drinks. What he eats must be an accepted part of his jati's diet and cuisine. From whom he will take food and with whom he will eat express his jati's status relative to that of cooks or fellow diners" (Mandelbaum 1970:196).

Food in Lakhimpukhuri-Jai-Kham-Dang village is basically divided in to two types - *khadya* and *akhadya* or *chala* and *nachala*. Literally, *khadya* means edible

and *akhadya* means not edible. But in practice *khadya* implies desired food and the latter is a tabooed food. *Khadya* and *akhadya* are relative to one another. What is *khadya* to a particular sect may be an *akhadya* to the other. For instance, among the members of the *Brahma-samhati*, pork, chicken, and rice-beer are *akhadya*, whereas, the same are *khadya* to the members of the *Kala-samhati* sect. Rearing of poultry and pigs and fermentation of rice-beer are taboo to the members of *khel-A*; although the members may partake such foods outside their house with or without the knowledge of the elders. It is often seen in this village that the children and other adult uninitiated members cook pork and chicken not in *juihal* but in cow-shed or *dhekihal* (an annex where paddy is husked in to rice).

Chala-nachala concepts are of recent use in this village. They are used in relation to a person's acceptance or rejection or restriction of certain kinds of food. The food here is one which is cooked by a person hired for the purpose, and who does not belong to the local community; or food prepared by an uninitiated person or food served by a person of different sect. This concept is mainly used when an affluent family in the village hires a cook from the city on occasion like marriage. In such a situation, provision of two types of food is made - one the *chala* type or

the traditional food prepared and served by the initiated members of one's own community; and the other - *nachala* or non-traditional or the *town-food* prepared by the hired cooks. *Chala* in Assamese means *one that could move*, and *nachala* means *one that can not*. If one could *move*, it implies that one has no restriction in accepting food prepared by a hired person; and if asked, he would say - *chala* and he/she is served with that kind of food. If *one can not move*, meaning that he can not accept such food and he would say - *nachala* and he is served with traditional kind of food.

Within the *khel*, an elderly person may not accept any food unless the person who serves has already been initiated as family cook. Food is again not accepted if it is not properly served with due respect. Normally when anyone is served, the place where food is placed is first mopped with water by hand. Person who serves should not put any footwear and should bow his/her head down while serving. This is done as a mark of respect to the person who is being served and to the food.

An orthodox *Vaisnavite* Ahom would not accept food from an another Ahom if the latter has not been initiated by a *Gosain* from the same *Satra*. Persons initiated by and affiliated to the same *Satra* on the same day and time

address one another as *Hari Bhakats* (see on Neo-Vaisnavism) and can accept food from each other, irrespective of the community to which they belong. For instance, a *Kachari* can readily be served food by an Ahom if the former is his *Hari-Bhakat*.

In this village Lakhimpukhuri (in short), since the two *khels* belong to two different sub-sects of *Neo-vaisnavism* and thus belong to different *Satras*; ideally an orthodox person from either *khel* would not accept food from one another. The two *khels*, on the basis of acceptance or rejection of certain food can again be broadly categorized in to two separate units - *keca* (*kuccha/raw*), and *sija* (cooked). These two concepts are used in relation to a group and to the type of *prashad* offered in certain rituals. For instance, the *prashad* offered on a *karani* (Fig.III/I) are usually pork , boiled rice and rice-beer. Such foods are known as *sija* and the group as *sija-manuh*. Whereas, the *prashad* offered on a *xarai* are fruits, parched gram and pulses, and are known as *keca*. The group here is called *keca-manuh*. The words *keca* and *sija* are also synonymously used to connote *malajapia* and *bhitarpakia* respectively. Restrictions on food can also be seen in certain other situations like birth, puberty, marriage, and death (see on beliefs and practices).

These concepts *keca* and *sija* as found in Lakhimpukhuri are not synonymous to the pan-Indian concepts of *kuccha* and *pucca* food where *kuccha*, although means raw does not always imply raw but "...imperfect food, 'kuccha' (Hindi), roughly speaking, for relatives or members of the endogamous group and servants of very inferior caste", and "...pakka (Hindi) the 'perfect food' consisting of pancakes fried in butter (puri) accompanied by vegetables fried in the same way, and also other dishes which are considered pure like parched grain..." (Dumont 1980:142).

Concept of *chua* with regard to food :

The concept *chua* may imply impurity in relation to birth, puberty and death. As regard to food it may connote left-overs or *zutha*. Unlike in other parts of India, where of course the " food that is left on the plate after a meal is tabooed to all, but leavings from the plate of one's father or husband, or leavings from offerings to gods are in quite a different class" (Carstairs 1957:80, cited in Mandelbaum 1970:199), in Lakhimpukhuri, this concepts of *zutha*, is understood in two different time situations; i.e., if a person touches a portion of his meal (adult males and children are first served their meals) it becomes *zutha*. He can offer a portion of his food to his youngers and to his wife. But if the same person leaves his seat without finishing his food, the left-overs become *chua*, and one may not accept that food. *Chua*, again, here can be treated as the food which has been touched and left behind.

C) Social Relations Through Beliefs and Practices

Beliefs followed by practices are the two basic elements that form the main body of any religion in what so ever form may be. These elements get reflected in the day to day activities and also in the rites of passage of any community. In the village Lakhimpukhuri, a beautiful co-existence of the Tai-Ahom and the Neo-vaisnavite faiths is seen; in certain aspects the two totally appear to be fused, in some other aspects the two appear to maintain their distinct characters; in a way the former forms still persist with some modifications and are well adapted to the popular faith giving entirely a new dimension to the religion which the adhere to.

Religious sentiments of the people of Lakhimpukhuri and their adherence to them can well be observed in their performance and participation in celebration of the rites of passage and in health and sickness. All these aspects of beliefs and practices as seen in the village are discussed as follows :

Birth :

Incident of birth in a family is an occasion of happiness in any society. Birth again is not simply a

biological phenomenon of conception, pregnancy and delivery. These are enveloped in sociological processes that entails a vivid socio-religious beliefs and practices. So sacred, yet so dangerously vulnerable is the mother (to be) during the period of her conception that she is hedged around with innumerable taboos.

Right from the day when a woman reports pregnancy, she is a taboo in the household; she is not allowed to enter the *majia* (see on commensal relations), she can not enter the granary and her membership in the *namhgar* (the community prayer hall) is temporarily suspended. Usually a pregnant woman is not allowed to move around freely, she is considered to be *chua* (impure). She is debarred from offering any kind of food and water to an elderly person. The restrictions remain until she completes a month after her delivery.

Ritual connected with conception

1. *Pitha-khowa* (ritual partaking of pound rice mixed with milk and molasses) :

This particular ritual takes place in the house of her husband when a woman formally announces her pregnancy to her mother-in-law. The mother-in-law would then invite three or five of her fellow women to her house. The

invitees would be seated usually in the *juihal* (see on commensal relations) and the expectant mother would then seat in front of them. A bowl of *pitha*, *gur* (molasses) and milk are placed just in front of the expectant mother. The invitees shower blessing on the 'mother-to-be' (blessings are actually the appreciation and acknowledgement of thanks to the God for his gift of a child that is going to come to this earth through this woman and that until the child is born, the mother and the child be protected from any kind of diseases), and each one of the ladies present, starting from the mother-in-law would then feed *pitha* to the woman. This ritual marks the count down of the actual delivery and is also an occasion to announce publicly the expectation of a birth in the family and it is observed on the 1st month of pregnancy.

2. *Panchamwrit-khowa* :

Panchamwrit is the most sacred and purifying mixture of five products of cow, viz., milk, curd, ghee, dung and urine. This ritual is performed after 5th or 7th month of conception, and it takes place in the natal home of the married woman. On this occasion the expectant wife visits her mother where she is given the *panchamwrit* to drink by her mother; no other invitee is invited on this day. Thereafter the lady goes back to her husband's place where she

finally delivers her baby. This ritual is performed in order to gain strength and vitality for the foetus which is growing inside the mother's womb. It is said that no women should deliver her child in her natal home as it is considered bad for the child. When asked, the villagers often quote the example from the great Indian Epic - *The Mahabharata*, that the lord Krishna was born in his mother's brother's house, and as a result of which misfortune fell upon him and his maternal uncle tried to kill him.

Rituals related to delivery

Apparently no ritual was observed at the time of delivery. But it was reported that once a lady had a delayed delivery and she was given a pot of water to drink and in which a stone which was struck by lightning was put. Such water, if given to a woman at the time of delivery is believed to ease child birth. This particular belief is very much popular among many Tai groups in South-east-Asia. For instance,

In central Thailand, a piece of stone or brick that has been hit by lightning is considered laden with beneficial magical power and can be used in the manufacture of amulets (Terwiel 1980:397).

The Assamese Tai namely the Khamyangs believe that if delivery is very difficult and the woman feels that it could be the result of her having offended her husband, a cup of water is fetched, the husband puts the big toe of his feet in the water for a while and later the woman drinks this water (ibid.:30).

Another case of slow delivery was reported in the village and this time the husband brought some exorcised water given by a Muslim exorcist which was then sprinkled and rubbed on the body of the woman in labour, and also the same was given to her to drink. In both the cases, the women after having the magical water were reported to have had safe and easy delivery.

In the Ahom village, traditionally a woman delivers her baby inside the house, but she is made to sleep on the floor on which a make-shift bed of paddy-hay is spread for her.

Rituals after birth

1. Cutting of umbilical cord :

In the village the elderly woman who attends to the cases of child birth, she usually cuts the umbilical cord with a bamboo sliver; it is not known to the villagers, like in the case of other Tai groups (*Khamyangs, Khanti, and Phakey*) the prescriptions pertaining to the way of procuring the piece of sharp bamboo. The village being nearer to the town Government hospital, mostly call for a trained nurse from the hospital. Today the village itself has a primary health center with a regular trained nurse and an ANM (Auxiliary nurse-cum-midwife).

Certain Tai groups of Assam are very particular about the piece of bamboo that is used to cut the umbilical cord. For instance, among the *Phakey*, they would like to obtain the bamboo sliver from the bamboo frame-work that upholds the roof, and it is important to cut off the piece with an upward stroke. While among the *Khamti*, they cut a piece of bamboo from the door post.

2. Disposal of the after-birth :

Disposal of the after-birth in a prescribed manner is an important aspect of child birth. During the fieldwork two children were born and it was noted that in both the cases after-births were buried after digging out pits in the backyard of the houses. The villagers believe that the placenta if not properly disposed may invite infliction by evil spirits through sorcery. Certain others in the village believe that 'in their times' (most of the informants are old-aged people and who keep think that the young ones have no faith and respect for the tradition) placenta was usually put in an earthen pot and buried. While certain others believe that it should be put in a bamboo tube and then plugged with plantain leaf and thrown in the river. If there is no river nearby, then the tube is buried within the backyard of the house.

The *Phakeys* have the practice of wrapping the placenta in seven pieces of banana leaves and then tying the same with seven bamboo threads is thrown in the river. In the absence of any river nearby the packet is buried.

3. Drying up of the abdomen :

As discussed earlier that the child birth in an Ahom village usually takes place on the floor, and as such after the birth of a child, a fire is made along-side the mother so that she can warm her abdomen. The process is known as 'drying up of the abdomen' or *uufai* - being near the fire (as among the *Khamyangs*, *Khamti* and *Phakey*).

4. Jaal-diya :

On the third day of the period of drying up, the mother is given a special food called *Jaal-diya* (meaning to serve something hot). It is a ritual that involves mainly the mother of the child, her natal parents who provide the main provisions for the special dish and the members of her husband's family. A special curry of fish (a large scale-fish is a must) is prepared with vegetable soda called *khar* (soda prepared from papaya or smoked peel of a certain variety of banana) and pepper. Another vegetable dish which includes one hundred and one varieties of leafy vegetables that grow wild in the garden and also the one which are cultivated is also prepared as a prescribed dish.

5. Introducing the child to the world :

This takes place after the child drops the remnants of the cut umbilical cord. This is a ritual of taking the child outside the house for the first time. *Baaz-ulua* is what they call in this village. *Baaz* in Assamese means outside and *ulua* means to come out. The ritual involves the mother, child and other elderly ladies of the house and the locality. A special wooden plate-form, locally known as *tamuli-pira* (Fig.III) of 2' X 4' X 6'' in size is placed towards east in the courtyard of the house. The ritual is organized in the early hours of the day. The elderly lady of the house, mainly the child's father's mother places a winnowing tray called *dola* upon which a lighted earthen lamp along with a pen, a book, and a bow and arrow or a needle and thread are kept. The ritual starts by striking a stone on the four corners of the plate-form accompanied by *uruli* by the women attending the ritual. The villagers give different meanings to this particular action; some says that it is important to strike the plate-form with a stone so that the child grows up to be as hard as a rock. Others are of the opinion that since the child on that day is taken out for the first time it is in a way, by striking the stone on the plate-form, the child is introduced to various possible forth coming situations that one may encounter in life.

The baby is then helped to touch a fountain pen, a book of religious rhymes - *Gita* or *Namanjali* (verses praising *Lakshmi* the goddess of wealth) in the case of of a boy, or a fountain pen, a similar book, a needle and thread in the case of a girl. The purpose of this ceremony is quite obvious. While introducing the baby to the wider world, it is also exposed to various elements of the world for a while. The objects that a baby is made to touch are the symbols of the kind of accomplishments that each gender is suppose to have.

Similar ritual of introducing the child to the world is prevalent among the other Assamese Tai groups. The Khamyangs call it 'Aw ook can'. Here too the ritual must be held soon after the remnant of the umbilical cord has dried and dropped off. The Khamyangs arrange in front of the ladder which leads up to the house, a number of objects to be touched by the child. If the child is a boy then the objects arranged are the various weapons like bow and arrow, a sword, a knife, an axe as well as a piece of rock, a book and a pen. If the new-born is a girl, the weapons are invariably omitted and instead a few baskets, needle and thread are kept.

6. Name giving ceremony :

Traditionally the Tai Ahom name bears two parts - the first is the name and second is the clan name. According to some scholars the Ahoms are divided into seven exogamous clans and hence the name 'sat-gharia' is commonly used. While naming a child certain prefix is added, for both male and female child, to the first name in order of birth. The first name is chosen by the Ahom priest after certain calculations based on the time and day of birth.

In the present village neither of the *khels* has any male or female bearing Tai name. Most of the names are given by the Brahmin pundits who are approached soon after a child is born with a *dakshina* (offering) which consists of a pair of betel nuts and leaves and a rupee and twenty five paise. Most of the names are common and often repeated in the sense that more than one person may bear the same name. Names of Hindu gods and goddesses often with suffixes like *nath* and *svari* such as Dinanath, Jaganath, Mahesvari, Bhugesvari etcetera are common. Females are also named after a flower, precious metal or any legendary figures. Common among the female names are Swarna, Kunja, Kunti, and Daivaki etcetera. All these names are given by the pundits based on astrological calculations.

These names are usually used after when the child grows up to a considerable age. There are other names with which a child may be addressed. These are the names of endearment. Moreover, a parent may sometimes give a child an ugly or inauspicious name owing to a superstitious fear that a child's beauty may provoke the envious glances or evil-eye of malicious persons. Certain names like Gedha - meaning bulky and heavy, Kalia - meaning dark or black, Gandhi - meaning a pest that emits foul smell, Katia - meaning short or dwarf, and Akani - meaning tiny are often given to a child whose actual appearance may or may not tally with the names given.

Besides these categories of names certain other uncommon names like Garia - meaning an out-caste or Bongali - meaning a tea garden labourer or foreigner are often chosen for a child. This happens in a family when quite often a child dies at an early age. The bereaved family would then on the advice of pundit, give the child to a Muslim or a Bongali on mortgage, and then name the child as Garia or Bongali as if the child is theirs. Such a practice is said to save-guard a child from the evil influence that the family is suffering with. Such belief is so deeply embedded in to the minds of the villagers that if the child survives to the adulthood has to be released on payment from the person to

whom it was mortgaged before marriage. Once such a person is released from the bondage s/he is given the customary bath and henceforth is accepted back to the clan. Otherwise no restrictions or social sanctions are imposed on the child bearing such names. It is customary to bring back a child to the clan, and s/he should no longer be addressed by these names.

7. Hudi or Annaprasana :

Hudi or Annaprasana is a ritual when the child is given the first solid food. It is a joyous occasion where presence of the mother's brother is vital. In the present village this ritual is performed in various ways. Considering the varied manner in which the ritual is performed and also seeing the lack of any occurrence of such ritual amongst other Assamese Tai groups, it may be assumed that the ritual is an adapted one. If that be so, then the question arises as to why the ritual was adapted. The issues arising out of such questions will be taken up for discussion later. At this stage let us present an account of the ritual as observed in the village.

In one occasion the ritual appears to be a simple get-together of a few elderly males or *bhakats* of the village in the house, who after performing *kirtana* partake

the specially prepared food after blessing the child and the parents. The child is then ritually fed with solid food.

In the second case, the process resembles the first, in which the child is introduced to the world or *baaz-ulua*. But in addition to that there is the role of the mother's brother. Mother's brother or *mama* plays an important role in this particular ceremony. Before the stipulated day on the sixth month of the child, the *mama* customarily presents the child with a pair of plate and bowl made of brass. If the child is the first issue of the couple, then it is customary on the part of the maternal grand-parent to present the child with gold ornaments on this particular day.

The ritual begins with the *mama* having been made to sit on the floor with his sister's child. The duo is usually surrounded by the members and relatives of the house. The paternal grand-mother then bring an winnowing tray(Fig.IV:Dola) on which a lighted earthen lamp, a book, weapons of various kinds, paddy with the stalk, ornaments and money are arranged for the ritual. The child is then helped to touch any object of his own choice. It is believed that whichever object the child touches first, s/he becomes a master of that object when s/he grows into an adult. Having

done this act varieties of food is served to the child on the plate and bowl that *mama* has presented. First the *mama* ritually feeds the child. He is followed by the paternal grand-parent who feeds the child after presenting a gift, and then the maternal grand-parent and others repeat the same. Later on, all the invitees are served with food specially prepared for the occasion.

B. The first hair-shaving :

The ritual of first hair-shaving was reported by an Ahom informant. Traditionally, in this village, first hair shaving has to take place on an auspicious day which is calculated by according to the child's date of birth and time. This usually takes place after the first year of birth or just after the child is given the first solid food. A large new bowl of brass is to be filled up with water up to the brim and some golden and silver ornaments have to be placed in the water. Then the child's head is washed in that bowl of water and then carefully shaven. The person who shaves the first hair of the child (usually a barber) is given gifts in cash and also the large brass bowl where the child's head has been washed. The shaven hair is then mixed with cow-dung, clay, and white mustered seeds and made into a ball which is kept stuck on the side-wall of the room where the baby sleeps. One of the informants says that this is done

with a hope to have a round and intelligent head, and the mustered seeds on it ward off the evil spirits. After the shave the child is ceremonially bathed as par Tai custom (see on Rik-khvan-mung-khvan).

Although the ritual hair-shaving is a sequential ceremony after birth, yet, today, people in the village do not go for this ritual. The ritual is not governed by any socio-religious sanction and hence is mostly seen amongst those who have the time and money.

Similar ritual hair-shaving is also reported among other Tais of Assam. The Tai Phakey or the Phakials follow the same process of washing the head but after the shave, the shaved hair is collected and thrown on the road-side. After this, the customary ritual to increase the child's vitality and strength is held. Other Tais like the Shans carefully preserve a tuft of hair in a little bag which is tied around the child's neck (Terwiel 1980:38).

Use of a barber to shave the child's hair seems to be a recent introduction. The kind of material tools that the locals use perhaps would be difficult for a man to shave with. Most probably, like the Shans and Thais, first hair might have been cut with knives.

RITUALS RELATED TO ADULTHOOD/NUA-TULONI-BIYA :

Nua-tuloni-biya, in Assamese, *Nua* means ritual bathing, *tuloni* means to be lifted and *biya* means marriage. It connotes 'being lifted from childhood to adulthood. This interestingly concerns only the female child. Among the Assamese Tais such ritual concerning male child seems to be completely absent; although certain terms like 'dekerua', meaning an adult goose, is often used to refer to an young man under teens, which is just one of the numerous colloquial term.

The very onset of menarche marks the beginning of the ritual. The girl on the day of menarche becomes *chua* (taboo/impure) and she is isolated and shifted to a corner of a room where, a special bed spread with hay, is laid for her. Initially she is debarred from partaking any solid cooked food for a period of three days. In these three days the only food that she gets is fruits. The occasion is accepted as happy one, although it remains sub-dued for the first three days. Girls of her age customarily gives company to her from the first day onwards, the act which is known as *suwali-parala-diya*, i.e., 'to guard the girl'.

On the fourth day, the girl is given a ritual bath, known as *saridinia-gaa-dhuoa* i.e., 'fourth-day

clothes and given the 'sindoor' (vermilion). All the lady invitees would then lift the girl and kiss her after presenting a gift. The girl is married to a banana tree which symbolically represents the groom. A big feast is given to the invitees on this day.

The purpose of this ritual is clear. The very act of public participation in the ritual may be interpreted as a kind of formal announcement that a girl has matured and is ready for seeking suitable matrimonial alliances. The ceremonial bathing is also an act which is supposed to increase the vitality of the woman. This is a ritual which is widely practised by the Assamese community.

MARRIAGE CEREMONY

The ritualistic part of an Ahom marriage as observed in Lakhimpukhuri is as elaborate as in any community in India. Since marriage is an important event and it is so very closely related to the socio-religious process, it is essential that all details of the ritual are noted for appropriate interpretation.

1. Tamul-Pelaboloi-Zua :

It is 'ritual offering' of areca-nuts and betel leaves by one party to the other during a visit made in

connection with marriage negotiation. Traditionally the Tai-Ahom sends emissaries or go-between with proposal to the bride's house and they carried areca-nuts and betel leaves with them.

Marriages in Lakhimpukhuri have been mostly through negotiations but cases of marriages by elopement within or outside the village are also not uncommon. In the case of arrange marriages that have taken place so far, it is observed that the use of go-between has declined significantly in the sense that unlike in the traditional way, a lineal member of the groom's family often accompanies the go-between, or the go-between may not necessarily accompany the groom's party at all. Never-the-less, the use of areca-nuts (complete with its stalk) and betel leaves seems to be an indispensable ritual, both when the marriage proposal is offered and one party visits the other for fixing date(s) of marriage. Moreover, the last three days before the actual marriage, both the bride and the groom are made to carry an areca-nut and a knife made of silver, along their waist line.

Ritual carrying of areca-nuts and betel leaves is essentially a south-east Asian trait and is still prevalent among many a groups in the world. The Lue on his marriage day carries a cluster of about one hundred betel nuts and the bride would do the same (Le May 1925).

The Siamese Tai groom visits the house of the girl three times carrying betel nuts and fruits and at the third visit relations of both the sides appear and count 'the portion of the bride' (Bride-price) and what is given to the groom (Schouten cited in Terwiel 1980:101).

The Thai of southern Thailand when sends an envoy to the prospective bride's house takes with him a container with areca-nuts and two fistfuls of betel leaves which are shared and eaten during deliberations (Terwiel 1980:102).

On the day before the actual marriage the Laotians, while carrying the bride-price over to the bride's house in a procession, take with them a hundred betel quids and tobacco as well as cakes, meat and fish, all of these covered with big paper cones.

The Neua young man when wishes to propose to a girl, his parents will have to send an emissary, a person well-versed in customs and lore, who will carry two packets of betel nuts, two packets chewing bark, forty-fifty banana leaf-cones, boiled rice, approximately one and half plasters in money, two dresses and a piece of silk (Bourlet, cited in Terwiel 1980:104).

Similar ritual carrying of areca-nuts is also observed among the Black Tai, White Tai, Red Tai and the Tho. The trait has also been well adapted by the other Assamese communities in the greater Assamese culture.

2. Jurun :

In Lakhimpukhuri two elaborate Ahom marriages were observed during the field work . The term *jurun* is an Assamese word which may in some way be equated to 'bride-price'. It is rather an occasion of presenting gifts to the girl and to her mother. In one case, on the first day the groom's party carried suitcases of dress materials and ornaments for the girl. Along with the dresses for the bride, one pair of clothings for the bride's mother was also taken as a mark of repayment of debt of that dress which the mother had already given to her daughter on the occasion of her *nua-tuloni-biya*. Besides, one earthen receptacle filled with rice and fresh mango twigs, each having five leaves, were also brought. It was also observed that the groom's party carried two *xarai* filled with one packet of black-pulse paste and one packet of turmeric each. They also carried one big fish to be given to the bride's father. The paste of black pulse-paste and turmeric were to be applied to the bride's body while giving her the ceremonial bath. After presenting the gifts the groom's party carried back one of the *xarai* with one

packet of black-pulse paste and one packet of turmeric to be applied to the groom's body while giving him the ceremonial bath in the evening (Plate:II).

The use of black pulse-paste and turmeric among the Tai-Ahom and other Assamese groups is similar to the pan-Indian. However, ceremonial bathing with water containing a variety of medicinal herbs and propitious substances such as an axe, tiger's tooth, and shavings from deer or buffalo horn, all of which have been stirred and sanctified by a priest's incantations were very much there among the Tai-Ahoms (Terwiel 1980:97).

Carrying of gifts or bride-price is common among the south-east Asian groups. Carrying of big fish is also found among the Shans. In a Shan's marriage, the elder members of the groom's party offer to the father of the bride a number of basketful of different kinds of food amongst which there must be four eggs and two salted fish (ibid 1980:99). This particular trait has been assimilated into the greater Assamese culture of today.

3. Chak-Lang :

Chak-lang is the main Ahom marriage ritual. It consists of a number of other rituals which are to be performed over a period of three days. On the first day, the

groom's party comes with the *jurun*. On the second day, oil is applied on the heads of both the bride and the groom (*murat-tel-diya*. Plate:1) and they are given a ceremonial bath at their respective places. Later in the evening, the bride and the groom in their respective places are made to sit in the pavillion made for the purpose and they are surrounded by the women of the village who sing *jura-nam* (an act of teasing through songs).

On the third day, actual marriage takes place at the bride's house. In Lakhimipukhuri, one such *chak-lang* marriage was recorded which is as follows : A welcome gate was constructed with fresh banana tree tied to two upright posts. The gate led to a huge pavilion in the courtyard of the house. In the center of the pavilion, a square-sized space, 3 feet on each side, demarcated by large slices of banana tree trunk, was created for the *chak-lang* ritual. The Square had four upright posts to which slices of banana trunk and sugar cane were tied putting the lower ends of the sugar cane in four bamboo tubes. On all the four sides of the square, on the upper part of the posts, a line of thread tied with mango leaf (*Aamdali*) at a regular intervals, was drawn. And on the top, a canopy with red border was placed to form the roof of the square. The space inside the square was filled with a number of concentric circles in

different colours mixed with rice powder. Then in the centre, a small round pedestal (*Maral*. Plate:III) was created. On the centre of the pedestal an earthen lamp with four wicks was placed in such a manner that its four wicks faced the four cardinal directions. Surrounding the central lamp, four smaller lamps were placed. Another set of 96 smaller lamps were placed concentrically the four former smaller lamps. Near each lamp, a *thuria-tamul* (cut areca-nut put inside a cone made out of betel leaf), a flower and a coin were placed. In total the entire arrangement has 101 lamps, 101 flowers, 101 *thuria-tamul* and 101 coins; the number which symbolized a large gathering of different gods and goddesses who witnessed and blessed the marriage.

At a time fixed by the priest to be auspicious, the bride's father was asked to light the central lamp and the priest with his assistants lighted the rest of the lamps. Meanwhile, the groom's party left his place for the bride's house. When they appeared in the bride's locality, the youngsters of the locality obstructed their way in to the bride's house (an act which is known as *dara-agosa*). The groom was made to answer a number of riddles and later released on payment of fine. Once he reached near the welcome gate, the bestman, known as *dara-dhara* had to hold an umbrella open to protect the groom from the onslaught of rice thrown to

him and his party. Then the bride's mother arrived and ceremoniously greeted her prospective son-in-law. His cheeks were wiped with betel leaf and flowers were placed on his head. Next, the groom was asked to put his feet on a small wooden plate-form and his feet were washed and wiped by the younger sister of the bride. The groom customarily paid some money for her service. Having done all these, the elder brother of the bride carried the groom, literally lifting him to the site of the ritual, where the other members of the groom's party were already seated. After a while, the groom's younger brother approached the women surrounding the bride and ceremonially requested them to bring the bride out in to the pavilion. The bride then appeared in the pavilion helped by a senior lady relative of her and was made to sit on the left side of the groom. Both the parties then formally accepted the priest as an officiant and the actual ritual began.

In this ceremony *sampradana* (the act of formally offering the daughter to the groom) is the main ritual. At the time of *sampradana* the father of the bride addressed the groom saying - "May god be the witness today when I am offering my daughter to you. Please do take care of her". The groom accepted the offer and said - "Here I accept your offer with due respect". Then the Tai priest who conducts the ritual gave a lesson on the rights and duties on

marriage in Tai language which was being simultaneously translated in Assamese by his assistant (Plate:IV).

After this ritual imparting of the lesson, the bride extended a sword to the groom and said - "With this sword may you be successful in protecting your nation, your wife and children and your dignity" (Plate:V). The groom acknowledged his thanks for the gift and said - "I swear on this sword that I shall eliminate evil, rule my citizens and protect my state and my religion". The bride then again offered him a shawl (Plate:VI) and said - "Oh my *Banghardeo* (a term of address to one's husband) please accept this piece of clothe as your shield and be triumphant". The groom accepted the shawl and assured her by saying that " I promise on this day that I shall fasten this piece of clothe as my belt and defeat my enemies".

After the formal rituals, the couple was led to a room where they were made to participate in a few customary games. For instance, a ring was hidden in a pot of rice and one had to take out the ring turn by turn (Plate:IX). After this game the bride and the groom tried to feed *jalpan* (a light meal) to each other in which both the participants were expected to resist (Plate:X). Whoever could feed the other first was declared as the winner.

As recorded among the Ahoms, the concept of ritual washing of feet of the groom on a wooden plate-form is also found among the Thai. The Thai groom of central Thailand gets his feet washed on a stone covered with a banana leaf at the foot of the ladder that leads to the house, and pays money for it. Similarly, the Tai of southern Thailand also gets his feet washed before entering the bride's house, by a child on payment of money. It is a gesture of welcome to the honoured guests (Terwiel 1980).

The obstructions of the groom's party by the youngsters is equally an interesting incident that is seen among the Tai groups. In central Thailand, the groom's party is often obstructed near the bride's house, and gets released only after the payment of a fee.

In southern Thailand, the groom may be intercepted by people who playfully hold a cord, a piece of cloth or a belt across the way, and he will have to pay an entrance fee before he is allowed to proceed any farther.

In traditional Laotian marriage, after arriving at the stairs, the groom has to pay some money for the right of entrance, and have his feet washed on a stone covered with a banana leaf.

Among the Neua, when the groom and his party arrive at the bride's gate, the young girls of the village spy their coming from hiding places and bombard the procession with soft fruits which have been drenched in an evil smelling liquid. The party may have to pay some money for their safe entry to the bride's house. Such obstructions and throwing of fruits or rice widely practised by the Assamese.

4. Suwali-poluwai-niya :

This Assamese term stands for one of the ways of acquiring mate for oneself. It is the marriage by elopement. As mentioned earlier, quite a good number of cases of marriage by elopement were observed in the village Lakhimpukhuri. This is a practice socially recognized as *suwali-poluwai-niya*. In such cases, although much heat is generated immediately after the incident; the act, though shameful, is condoned by a socially recognized ritual called *sur-dhara*, meaning 'to catch the thief. The girl's parent visits the boy's house and customarily accuse the boy of the theft. A few elderly members of the village are summoned. In their presence the boy's parents ceremonially greet the accusing party and plead for forgiveness by saying that their son is an 'absolute fool' on earth and that they are extremely shameful for what he has done and are equally sorry to have

hurt their feelings; but what is done can not be undone and now that they have accepted the girl as their daughter-in-law, it is better for both the parties to accept the relation (i.e., being affines).

The couple appears and prostrate before the girl's parents with a *xarai* in which two pairs of areca-nut and betel leaf are placed, and also with a sum of Rs 10/15 as a symbol of fine paid for the act of theft, and a pair of *gamucha* (Assamese towel). All these are presented to the girl's parents. This calms down the situation and the girl's parents while accepting the gifts bless the couple by saying - it is a very unfortunate thing to have happened, but what has happened happened; and one could only wish them a happy and a prosperous married life.

In one such incident during the course of fieldwork, a 20 year boy who is posted as a forest guard in a place some 20 Kms away, eloped with a girl of 18 years in age and brings her to the village. On reaching Lakhimpukhuri, the boy did not dare to face his parents and therefore, turned back and took the girl to his maternal uncle's place, some 8 kms away in an another village. After three days the couple accompanied by the maternal uncle returned to the village when they were finally accepted by the parents with the help of the

uncle who advocated for their cause. The girl's parents appeared after an week to complete the ritual of 'catching the thief'. Later the couple was socially accepted by the villagers when they prostrated before a gathering of *bhakats*.

CHAPTER V :

AHOMS TODAY : II

Rituals Concerning Death :

* 'Tiloni'

* 'Daha'

* 'Mahekia-Hakam'

Rik-Khvan-Mung-Khvan

Festivals And Associated

Rituals:

* 'Goru-Bihu'

* 'Husori'

Village Community Life And

Associated Rituals :

* 'Nam-Ghar'

* Concept Of 'Haori' In

Community Living

THE AHOMS TODAY : II

This chapter is in continuation to the earlier chapter and presents more on the beliefs and practices which are associated to the village community life.

RITUALS CONCERNING DEATH

Traditionally, the Ahoms followed the practice of burying the corpse and up to the middle of the eighteenth century even the kings were buried. The kings used to build mausoleum, known as *maidam* in Assamese, for their deceased members of the royal family in which the corpses were laid in coffins along with some food and wealth. Later they became Hindu and cremation became a common practice.

In Lakhimpukhuri, according to a Tai-Ahom informant, until recently, some twenty years back, dead bodies were initially buried for six months or so and later bones were collected and cremated. Today, in the case of any death in the village, cremation is the only practice followed except in the case of children and infants who are buried.

A detail record of death ritual which was recorded in the field is presented as follows :

An old lady of 65 years died after a prolong ailment of kidney failure. While taking the body out

of the house, her head pointing towards east and the feet towards west. The corpse was washed by an elderly lady of the house with cold water, dressed in garments of good quality and was covered with a piece of new cloth. A few grains of paddy were brought and by holding the right hand of the deceased the grains were passed through the inter digital space. This was repeated for the left hand and after collecting the grains they were kept in the granary for three days. Three days later they were to be inspected carefully. If the grains decreased, it was a sign that the deceased had taken some of her wealth and bad days might be fallen upon the family; if the number of grains remained the same, no change was expected and if the number increased the family would prosper in the following years.

A bamboo stretcher called *changī* was woven for the corpse to be carried to the cremation ground. While the corpse was on the *changī*, the gathered *bhakats* of the village, specially the one taken to be the *medhi* gave a long deliberation on the good nature and deeds of the deceased person when she was alive. After a short prayer for the safe departure of the soul to the heaven, the body was taken for the last rites to the cremation ground. Four persons, specially the two sons in front and two other fellow villagers in the back shouldered the stretcher, followed by the other

male members of the village. One of the sons carried a lighted torch made of hay bundled together, called *jumuthi* in Assamese.

Meanwhile, all the cooked and uncooked food from the kitchen and even the fire in the hearth, were cleared and 'thrown out'. An earthen lamp was lighted and kept facing east on the spot where the corpse had rested before. The lamp was kept glowing for three days. A pitcher (called *kalah*) of water was also kept outside for three days for the departed soul which was believed to wander around the courtyard for three days.

After reaching the cremation ground, fire wood was gathered by felling trees around the place and a pyre was laid for cremation. It was noticed that the persons who shouldered the stretcher were prohibited from cutting the wood. The corpse was then carried around the pyre for five times and was finally laid on the pyre. The eldest son who carried the torch lights the pyre first. Rest of the members who were present, threw a piece of wood in the fire one by one, and finally when the body got burnt completely, ashes were collected in an earthen pitcher (*tekeli* in Assamese) and was brought back home for further ritual.

All the members who participated in the cremation rite, after leaving the ground, watered themselves from head to toe with their clothes on and jumped over a large fire made in the courtyard of the deceased person's house before entering in to their respective houses. The lineal relatives of the deceased person mourned and abstained from cooking for three days. Persons affected by this ritual 'abstaining of cooked food' were usually the husband of the deceased person, her sons and daughters (including those who are married and happens to be nearer to their natal home), husband's siblings and their wives and children. On the third day, first purificatory ritual called *tiloni* was held. Some ritual water called *shantiyani-pani*, sanctified by a Brahmin's incantations was brought and given to all the members of the house to sip a little and to apply the rest on head.

During these three days of mourning and abstaining from cooking, friends and other fellow villagers supplied the family with 'rice-powder', parched grams and fruits to be eaten. From the third day evening, family hearth was again lighted and ordinary food without oil, spices and meat or fish, was served until the third purificatory rite was performed on the 30th day. Meanwhile, the eldest son of the deceased abstained from shaving or getting his hair cut, from sleeping on a bed, from sitting on a chair, from putting any

upper garment and shoes. This continued until the second purificatory rite was performed, and during this period he took only one meal a day (*baratia-bhat*) in the evening which he cooked himself outside the house in a broken earthen-ware.

On the 10th day, second purificatory ritual called *daha* was performed. A Brahmin was invited to perform the *dasha-pinda* rite where the priest along with the eldest son went to a nearby water source. There he mixed the 'mortal remains' with rice powder and made them into five balls (*ladu*) and after chanting certain *mantras* asked the deceased son to throw them into the water one by one. This took care of the ashes which have been brought from the cremation ground.

Meanwhile, in the house, friend and relatives gathered with gifts like banana, coconut, grams etc., for the ritual to be followed later during the day. All the gifted items were cut and placed on a *xarai* facing east. The ceremony was devoid of any *kirtana* (devotional songs) and all the lineal relatives prostrated before the gathering of the *bhakats* and the guest departed after partaking the *prashad*.

The third purificatory rite called *mahekia-hakam* was observed on the 30th day. A large number of

friends and distant relatives took part in the ritual with gifts of fruits and other eatables. Early in the morning the sons of the deceased got their hair completely shaven. A huge pavilion was erected in the courtyard and guests were seated along with the *bhakats*. An alter called *thapana* was established by placing a *xarai* on which a holy book of religious rhymes, one rupee twentifive paise as *guru-dakshina* and two areca-nuts and betel leaves were kept covered with a *gamucha*. All the gifts that were brought for the ritual were placed before the *thapana*. The entire day was spent in singing *nam-kirtana* and later in the end, the entire family including the patrilineal relatives prostrated before the *bhakats*. The ritual ended after distribution of *prashad*. A special share of *prashad* was also placed in the name of the departed soul which was later thrown in the backyard to be eaten by animals and birds. Late in the evening, a feast was given to the invitees in honour of the departed soul. Ritual re-entry of non-vegetarian food was very conspicuous on this day with the prescribed dish of fish.

Henceforth, the family observes the annual death anniversary of the deceased person which is known as *baserekia*.

The death rituals as observed in Lakhimpukhuri present an example of assimilation of the local version of the Hindu rituals and the archaic Tai. For instance, washing of the deceased's body and putting of new clothes is similar to most of the Hindu or other communities in India. Traditionally in the case of a death in a family, when the body is taken out, three packets of paddy-straw containing 3, 4, and 7 grains of rice are respectively carried in an winnowing basket to the corpse and the deceased hand is taken and rubbed over the baskets whilst imploring him not to take the goddess of wealth away, but to leave the house in prosperity (Gogoi 1976:89). This is a South-east Asian trait which the Ahoms still maintain along with the other Hindu rituals.

The use of sanctified water as seen in our earlier discussion, by the Ahoms is very much common among any Hindu community. Keeping an earthen lamp glowing on the spot where the body of the deceased is laid outside the house is a practice similar to the one found in the mausoleum of the deceased kings where a lighted lamp was kept.

Re-entry of fish and meat in the feast given on 30th day is also a survival of the Tai trait which is also found among other south-east Asian Tais.

Many a Tais of south-east Asia bring back the ashes in an earthen pot to bury the same after performing certain ritual. The same Tai ritual is seen among the Hinduized Tai-Ahoms in the form of the ritual - *dasha-pinda* performed on the 10th day.

Ritual washing of the dead body is not only a Hindu trait but is also equally seen among other Tai groups. The Khamyangs wash their corpse with turmeric water and tie the thumb and toes with white thread. The Phakeys wash with cold water and use white thread to bind the hands and feet together. The Khamtis wash the corpse and when they dress the deceased, the clothing is turned inside out and may be ritually destroyed by slightly tearing them. The Shans wash the corpse with scented water and dress with new clothes which are slightly torn (Milne 1970:97).

The Lue ritually wash and then the deceased in new clothes. They also tie both hands and toes with white threads (Le May 1925:191).

The Yuans wash the corpse with cold, previously boiled water. New dress is put on reversely, i.e., with buttons on the back (Keyes 1975:53-4).

The Tais of southern Thailand wash their corpse with water in which various medicinal leaves have been placed, and dress in its best clothes, but the clothing is reversed (Cittatham 12 Sangkla:83:6).

The Tais of north-eastern Thailand use water boiled with tamarind leaves and cool it to wash the corpse. The body is dressed in reverse manner. The big toe, knees, elbows and neck may be tied with cotton thread (Rajadhan 1957:412).

The red Tai washes the dead with warm water which contains vine leaves and dresses it in new clothes. The kitchen stove is disturbed and placed in disorderly manner. The white Tai too washes their corpse with water soaked with vine leaves. The kitchen stove is taken out of the house (Terwiel 1980:161).

Rik-Khvan-Mung-Khvan : a Tai-Ahom ritual

Rik-khvan-mung-khvan is a traditional Tai religious and cultural ceremony. *Rik* in Tai means 'to call', *khvan* means life/longevity/soul and *mung* stands for the state/country. Thus, *Rik-khvan-mung-khvan* means a ritual performed with a wish to enhance or to call back prosperity

and longevity of the state or a person. It is also known as *Rik-khvan-mung-khvan-ban* at times. *Ban* means a village. Now the word *Rik-khvan-mung-khvan-ban* means a ritual to call back or to wish longevity and prosperity for all the hamlets and villages that constitute the state. It is basically a ceremony to propitiate Lengdon, the god of heaven who is worshiped by sacrificial rites to get the grant of long life and prosperity to the king and his subjects and the country.

In the Ahom chronicles, *Rik-khvan-mung-khvan* as a ritual has a special place. The two sons of the lord, *khun-lung* and *khun-lai*, when sent down to earth by their father Lengdon from heaven were advised to perform this ritual whenever one committed sin. A person was considered to be spiritually dead whenever he committed any sin. In such a situation, his life had to be called back. Accordingly, one had to sacrifice and offer 10 cows to the lord Lengdon and give a feast to his fellow men with beef and buffalo meat. The titular deity *Sang-deo* was bathed and that water used was drunk. One could get purified or one's life or soul could be called back after the above mentioned rituals were performed.

Traces of Rik-Khvan-Mung-Khvan as seen today :

After the decline of the Ahom kingdom, *Rik-khvan-mung-khvan* in its traditional form is hardly

performed by any, excepting those who want to revive the ancient Tai tradition. Traditionally, it was a prerogative of the royal family only, who could perform this ritual. Nevertheless, it is not a dead ritual either. Today, at the family level, it is present among the priestly Ahom clans - the Deodhai, Bailung and Mohan, who even after adapting Vaisnavism, still perform this ritual as *ikhon*. Amongst all other Ahoms if marriage is solemnized in traditional Tai way, i.e., *chak-lang*, it is customary to perform *Rik-khvan-mung-khvan* and *aptang* (ceremonial bath). Today, this ritual is popular among the Ahoms and also among the other Assamese as *pani-tual* and *nuoa*.

Moreover today, the ritual in its partial and modified forms are performed by every Ahom family. One may over look its original and historical form and objectives, but at a number of occasions this ritual is seen in every household. For instance, if a person ever gets drowned and he is shocked, or if a person is bed-ridden for a considerable time, then the elderly women in the village, go in a procession, to the nearby water source and after propitiating the water god *Khaokham*, draw water to give a ritual bath to the sick person so as to call back his 'life' or to enhance his vitality.

Similar ritual is also observed in order to get a better yield in the fields and fisheries and for an overall prosperity of the village. The village folks take out a procession singing with the beating of drums and goto a water spot. There, with a *jakoi* (a triangular fishing implement made of bamboo) they draw water. The ritual is known as *Lakhimi-tula* (to lift the goddess of wealth). The implement is drawn up, water percolates down and anything that remains on the netted surface is carried back home as *Lakhimi* and is stored in the granary.

In villages whenever there is an occasion of community feast, after finishing their food the villagers carry the leftovers and throw them into the river. This disposal of the leftovers into the river is believed to eliminate bad omens from the village. The practice is also followed whenever there is an epidemic in the village.

All these independent activities are actually *Rik-khvan-mung-khvan* in its vivid and diluted forms. These rituals have now become a part and parcel of the greater Assamese culture.

Indira Baruah write about the ritual as :

...is one of the most important religious ceremonies performed by the villagers. It is meant particularly for the Ahom god Lengdon. This ceremony is performed with a wish to get prosperity and

happiness for the family". And... in early days, Rik-Khvan-Mung-Khvan was performed by the Ahom kings on the occasion of victory in a war or at the installation of the new king. It was also performed to wish a long life to the king. Now, the ahoms perform it for the welfare of the family (Baruah 1978:93). And...

"...if a child gets a shock from a particular object they think that the soul is disturbed. They arrange to call back the soul by a certain ceremony called 'Ayu-tula'. In this ceremony, they propitiate the god Khaoxhom (god of water) and invoke him to restore the soul in the original-normal place and to grant a long life (Baruah 1978:96).

In short, the ritual can still be found among the Vaisnavite Assamese Ahoms within the framework of the greater Assamese society, and yet stands 'typical' when the Ahoms perform it. The inherent objectives of the ritual are :

1. When it is one's question of life and death in acute cases of sickness.
2. When one is spiritually dead (by committing sin).
3. When there is severe loss of lives and wealth in the state.
4. For personal, social and state's economic prosperity.
5. To eliminate bad omens and evils of life at personal or at the state level.
6. To get rid of inflictions due to evil deeds, spirits, deities and planetary influences.
7. For all these reasons, propitiation of Lengdon and Khaoxhom is needed through *Rik-khvan-mung-khvan*.

Bohag-Bihu :

Bohag-Bihu is more an occasion of fun and merry making than a ritual. This is a festival which is celebrated in the month of Bohag/Vaishak (April/May). With a few more days left to go back to the fields for tilling the soil for cultivation (that starts from Jun/July), the young men and women of the village come out in groups dancing and singing. It is basically a festival of the young. It is the occasion when they exchange their love through Bihu songs.

Associated with this occasion of dancing and singing are the two rituals called *goru-bihu* and *husori* which command equal importance as any other rituals in the village.

Goru-Bihu :

It is a ritual concerning the cattle of the house, the cows and buffaloes. On the last day of the month *chot* (March/April), every household cattle is taken out to the water side and given a ceremonial bath while throwing slices of brinjal and water gourd which are pierced through by a pointed bamboo needle and sing :

"Lao kha, bengena kha,
basore, basore barhi za
mar saru, baper saru,
toi hobi bor goru".

Meaning that you may eat water gourd and brinjal and grow up every year. Your mother and father are of inferior breed but you may grow up to be of a better breed.

Later in the evening, the cow-shed is properly mopped and the cattle are tied with new ropes. Twigs of certain medicinal plants (locally known as *makhi-sal*) are kept hanging on from the cow-shed to ward off diseases.

Husori :

The concept of *husori* started when the common peasantry in groups visited the kings and the nobles to bless them with prosperity and good health by singing and dancing Bihu dance. Today, groups of young men and women and even the elders maintain this spirit by visiting every household in the village and wish them good health and prosperity. Since there are no more kings and nobles today, they start the *Husori* by visiting and blessing the most respected and revered person in the village first, the *medhi* of the village. Then comes the *gaon-burha*, the village headman followed by other person's house in order of seniority in age. Whenever a *husori* comes to a house, it is considered to be an auspicious moment for the family. All the members of the family prostrate before the *husori* and offer on a *xarai*, a pair of areca-nut and betel leaf and a some money according to one's availability of means, covered with a piece of cloth known as *xarai-dhaka*. The members of the *husori* showers blessings by saying :

" Now that the Husori has come to this house and it is being welcomed with whatever possible means the family could afford; the Almighty may fulfill all their wishes and may help in keeping up the same

spirit of good-will, of being a good host, and means to welcome it in years to come. For the welbeing of the host, glory to the lord Rama, glory to the lord Hari".

Most of these forms of rituals, which the Tai-Ahoms have so intelligently adopted from various cultures of Assam, retain their own traditional world-views, it is the survival of the old values in new forms.

VILLAGE COMMUNITY LIFE AND ASSOCIATED RITUALS :

Life in any village is never isolated, this is very much evident from a number of social activities that revolve round the year. These activities may take place at personal, social, religious or at the economic level. Two such institutionalized social activities are the *Namghar* and *Haori*.

Namghar :

Namghar is the seat of religious activities within the *satra* (Sarma 1966:101) and its extension to every village is the index of successful spread of Vaisnavism amongst various communities in Assam.

In Lakhimpukhuri the *namghar* is headed by a *medhi* who is usually an elderly man initiated by a *guru* from the *satra* to be the *medhi* of the village *namghar*. He is

assisted by a *namgharia* - one who takes care of daily cleanliness of the place and lights the lamp in the evening. All other members of the village, unless one is excommunicated, are the *bhakats* (disciples).

Within the village, as and when required, the *medhi* summons a gathering of the fellow *bhakats* and discuss about their religious activities. *Namghar* is also used for hearing and resolving any socio-religious disputes within the village and accordingly *danda* (fine/penalty/punishment) is declared unanimously.

It is through the *namghar* that the annual subscriptions to the parent *satra* are collected as *guru-gharar-dakshina*, a practice which has been going on since the inception of the *satra* institution by the saint Shree Shree Sankaradeva.

It is here again that the community participation in various religious activities like *makar-sankranti*, *janmasthanmi*, *pal-nam* and *nam-kirtana*, can be seen.

Makar-Sankranti or Magh-Bihu :

It is a festive occasion rather than a ritualistic one. It falls on the last day of the month *magha*

(December/January), when the village folks gather in the courtyard of *namghar* for a community feast. It is rather taken to be a harvest festival and commonly known as *maghar-bihu*. The occasion has a religious aspect too. The day after the community feast, in the early part of the day a huge fire is burnt in the courtyard of *namghar*. Young boys of the village construct *bhela-ghar* (small make-shift house made of paddy hay and bamboo) in the paddy field where they feast in the night and burn the same in the morning. This is done with a view to drive away winter and to welcome the warmer days ahead. All the members of the village, old and young alike, gather after having bathed with smeared paste of turmeric and black-pulse and prostrate in front of the fire after offering a pair of areca-nut and betel leaf with a coin to the fire. The *medhi* of the village prays for the wellbeing of the village and its people. It is customary to eat roasted sweet potatoes and fried black-pulses near the fire. Otherwise, the villagers say that one will be born as pigs in his/her next life. Firing of *hilo* (cannon) in this fire is a game of fun for the children. A *hilo* is a piece of solid bamboo when put into the fire bursts open with a huge sound that resembles a cannon.

Bihu-Jalpan-Karua :

Maghar-bihu which is also known as *bhugali-bihu* (*Bhugali* is an adjective that connotes abundance in food materials) which is celebrated immediately after the

harvest. *Bihu-jalpan-karua* is a ritual offering of the harvest in the form of *jalpan* (consists of either *chira* - flattened rice or *kumal-choul* i.e., parched rice with curd and molasses) and other items of *pithas* (made of rice powder by baking with sesum mixed in molasses), to nine *bhakats* of the village that represent nine ancestors of the Ahoms. Every family partakes their *jalpan* after offering it to the *bhakats* first.

Later in the evening, it is customary to tie a thread around any fruit bearing tree. By doing so, it is believed that better yields of fruits in the orchard will follow. People also tie a thread around a post of their house which is again believed to protect the house from natural calamities like flood, typhoon, earth-quake etc.

Janmasthanami :

Janmasthanami is observed in the village with much pomp and gaiety. This falls on the eighth day of the dark half of the month of *bhado* (August/September). On this occasion the village folks gather in *namghar* and participate in the *nam-kirtana*.

Pal-nam :

The practice of *pal-nam* may be equated with the *akhanda-kirtana* (singing devotional songs without a

break). But in Lakhimpukhuri, *pal-nam* stands for - *pal* meaning 'turn', and *nam* means devotional songs written by Sankaradeva and Madhavadeva; i.e., organizing *kirtana* 'turn by turn' or by 'shifts'. This is an annual practice and is organized either by all-male or all-female members of the village for the wellbeing of the village and its people.

Nam-Kirtana :

Nam-kirtana at the individual family level is the offering of *prashada* among the *bhakats* in *namghar*, where a number of *bhakats* are invited to take part in *kirtana* meant for the welfare of the family who organizes it.

Namghars may also be seen as a camp office of the parent *satra* whenever any *gosain* (preacher of Sankaradeva's Neo-Vaisnavism) makes a visit with the purpose of initiating new disciples.

Concept of Haori in community living :

The etymological meaning of the word *haori* is not known from the village. Nevertheless, the concept refers to a corporate functional unit within the village. In Lakhimpukhuri, it was used as *haori-lowa*, i.e., 'to take *haori*'. It was observed during the fieldwork that an individual family may take *haori* at times when it needs a

collective endeavor of the village folks. Instances of *haori* were recorded and found that they were usually employed in the following circumstances :

1. Transplanting seedlings : When the working members of the family are few, sick or absent, one may take *haori* to accomplish the job of transplanting seedlings to the fields. The invited members come and help out of their own good will and are given a good meal with meat and rice-beer.
2. Harvesting : Due to the similar reasons one may take *haori* to harvest one's fields.
3. Construction and repairing of houses : Taking of *haori* is also seen at the time of constructing new houses and for repairing the old ones.
4. Marriage : For such help in a marriage, one may seek participation of the villagers in a *haori* by offering a pair of areca-nut and betel leaves in front of a gathering of *bhakats* in the *namghar*.

Infact, whenever a *haori* is taken or for that matter, any invitation that is being extended to a villager, should be preceded by an offering of a pair of areca-nut and betel leaves. It is a gesture of honouring the person who is invited. The village folks take offense if one is invited verbally without areca-nuts and betel leaves.

The Ahom villages have always been a corporate unit. Even under their monarch, the *paik* or *khel* system (refer to social organization of the Ahoms) encourages corporate manual labour. With the advent of *satra* institutions when *namghars* are established in the village,

such corporate 'helping' is highly encouraged and is still prevalent in the villages.

Kinship :

The Ahoms today, as seen in the present village Lakhimpukhuri, are not divided in to *phaid*s and sub-*phaid*s. These *phaid*s and sub-*phaid*s are so dispersed that the individual families today, stick to their 'Localized lineages' based on more or less Hindu *Sapinda* rule. This prohibits the union of any two persons who have a common ancestor not more than six degrees removed on the male line or four degrees removed on the female line. They are also assigned a *gotra* (Kindred) - *Kachayapa*. Interestingly, all the Ahoms of Assam fall under this single *gotra* (?).

Ahoms Kinship system till today maintains its earlier characteristics (as discussed in Chapter III) to a large extent. In the present village this is quite evident from the kinship relations that they maintain and the terms they use. Although, most of the affluent Ahom families tend to use modern Assamese terms for the kins. In the present village following kinship terms are recorded with the help of a genealogical chart.

From the chart (see appendix) collected from the village when traced through the person IV/25 we have the terms as :

| <u>Relations</u> | | <u>Terms Of Address</u> |
|---------------------------|---------------|--------------------------|
| <u>Terms of Reference</u> | | |
| I/1 = FaFa | <i>Kaka</i> | <i>Kakadeota</i> |
| 2 = FaMo | <i>Aita</i> | <i>Aita</i> |
| 3 = MoFa | <i>Putha</i> | <i>Puthadeo</i> |
| 4 = MoMo | <i>Enai</i> | <i>Enaideo</i> |
| II/1 = FaZ(y) | <i>Feh1</i> | <i>Fehideo</i> |
| 2 = FaZ(y)Hu | <i>Feha</i> | <i>Fehadeo</i> |
| 3 = Faz(e) | <i>Apa</i> | <i>Apadeo</i> |
| 4 = FaZ(e)Hu | <i>Nisa</i> | <i>Nisadeo</i> |
| 5 = FaBr(y) | <i>Dadai</i> | <i>Dadaideo</i> |
| 6 = FaBr(y)Wi | <i>Khuri</i> | <i>Khurideo</i> |
| 7 = FaBr(e) | <i>Borta</i> | <i>Bordeota/Nichadeo</i> |
| 8 = FaBr(e)Wi | <i>Borma</i> | <i>Borma/Apadeo</i> |
| 9 = Fa | <i>Pitai</i> | <i>Deota</i> |
| 10 = Mo | <i>Ai/Ma</i> | <i>Ai</i> |
| 11 = MoBr(e) | <i>Nisa</i> | <i>Nisadeo</i> |
| 12 = MoBr(e)Wi | <i>Apa</i> | <i>Apadeo</i> |
| 13 = MoBr(y) | <i>Momai</i> | <i>Momaideo</i> |
| 14 = MoBr(y)Wi | <i>Maideo</i> | <i>Mamideo</i> |
| 15 = MoZ(e) | <i>Apa</i> | <i>Apadeo</i> |
| 16 = MoZ(e)Hu | <i>Nisa</i> | <i>Nisadeo</i> |
| 17 = MoZ(y) | <i>Mahi</i> | <i>Mahideo</i> |

| | | |
|------------------|-----------------------|--------------------|
| 18 = MoZ(y)Hu | <i>Moha</i> | <i>Mahadeo</i> |
| III/1 = FaZ(y)So | <i>Bhaiti</i> | <i>Bhai</i> |
| 2 = FaZ(y)SoWi | <i>Buwar1</i> | <i>Bhai-Buwar1</i> |
| 3 = FaZ(y)Da | <i>Bhani</i> | <i>Bhani</i> |
| 4 = FaZ(y)DaHu | <i>Boinai</i> | <i>Bhani-juwai</i> |
| 5 = FaZ(ə)So | <i>Kakaideo</i> | <i>Kakaideo</i> |
| 6 = FaZ(ə)SoWi | <i>Bow</i> | <i>Bowdeo</i> |
| 7 = FaZ(ə)Da | <i>Bai</i> | <i>Baideo</i> |
| 8 = FaZ(ə)DaHu | <i>Bhini</i> | <i>Bhinihideo</i> |
| 9 = FaBr(y)So | <i>Bhaiti</i> | <i>Bhai</i> |
| 10 = FaBr(y)SoWi | <i>Buwar1</i> | <i>Bhai-buwar1</i> |
| 11 = FaBr(y)Da | <i>Bhan1</i> | <i>Bhani</i> |
| 12 = FaBr(y)DaHu | <i>Boinai</i> | <i>Bhan1-juwai</i> |
| 13 = FaBr(ə)So | <i>Kakaideo</i> | <i>Kakaideo</i> |
| 14 = FaBr(ə)SoWi | <i>Bow</i> | <i>Bowdeo</i> |
| 15 = FaBr(ə)Da | <i>Bai</i> | <i>Baideu</i> |
| 16 = FaBr(ə)DaHu | <i>Bhini</i> | <i>Bhinihideo</i> |
| 17 = Z(y)Hu | <i>Boinai</i> | <i>Bhan1-juwai</i> |
| 18 = Z(y) | <i>Saru-bhan1</i> | <i>Bhanti</i> |
| 19 = Z(ə)Hu | <i>Bhini</i> | <i>Bhinihideo</i> |
| 20 = Z(ə) | <i>Bai</i> | <i>Baideo</i> |
| 21 = Br(ə) | <i>Kakai/Ka1/Kaka</i> | <i>Kakaideo</i> |
| 22 = Br(ə)Wi | <i>Bow</i> | <i>Bowdeo</i> |
| 23 = Br(y) | <i>Bhait1</i> | <i>Bhai</i> |
| 24 = Br(y)Wi | <i>Bowar1</i> | <i>Bhai-bowar1</i> |

| | | |
|-------------------|-----------------|----------------------------|
| 25 = Ego | -- | -- |
| 26 = EgoWi | <i>Hera</i> | <i>Parivar/Patni</i> |
| 27 = MoBr(ə)So | <i>Kakaideo</i> | <i>Kakaideo</i> |
| 28 = MoBr(ə)SoWi | <i>Bow</i> | <i>Bowdeo</i> |
| 29 = MoBr(ə)Da | <i>Bai</i> | <i>Baideo</i> |
| 30 = MoBr(ə)DaHu | <i>Bhini</i> | <i>Bhinihideo</i> |
| 31 = MoBr(y)So | <i>Bhanti</i> | <i>Bhai</i> |
| 32 = MoBr(y)SoWi | <i>Buwarī</i> | <i>Bhaibuwarī</i> |
| 33 = MoBr(y)Da | <i>Bhanti</i> | <i>Bhani</i> |
| 34 = MoBr(y)DaHu | <i>Juwarī</i> | <i>Bhani-juwarī</i> |
| 35 = MoZ(ə)So | <i>Kakaideo</i> | <i>Kakideo</i> |
| 36 = MoZ(ə)SoWi | <i>Bow</i> | <i>Bowdeo</i> |
| 37 = MoZ(ə)Da | <i>Bai</i> | <i>Baideo</i> |
| 38 = MoZ(ə)DaHu | <i>Bhini</i> | <i>Bhinihideo</i> |
| 39 = MoZ(y)So | <i>Bhanti</i> | <i>Bhai</i> |
| 40 = MoZ(y)SoWi | <i>Buwarī</i> | <i>Bhai-buwarī</i> |
| 41 = MoZ(y)Da | <i>Bhanti</i> | <i>Bhani</i> |
| 42 = MoZ(y)DaHu | <i>Juwarī</i> | <i>Bhani-juwarī</i> |
| IV/1 = FaZ(y)SoSo | by name | <i>Bhatija/Bhatijapu</i> |
| 2 = FaZ(y)SoDa | by name | <i>Bhatija-suwali</i> |
| 3 = FaZ(y)DaSo | <i>Bhagin</i> | <i>Bhagin/Bhaginlora</i> |
| 4 = FaZ(y)DaDa | <i>Bhagini</i> | <i>Bhagin-suwali</i> |
| 5 = FaZ(ə)SoSo | by name | <i>Bhatija/Bhatijalora</i> |
| 6 = FaZ(ə)SoDa | by name | <i>Bhatijaji</i> |
| 7 = FaZ(ə)DaSo | <i>Bhagin</i> | <i>Bhaginlora</i> |
| 8 = FaZ(ə)DaDa | <i>Bhagini</i> | <i>Bhagin-suwali</i> |
| 9 = FaBr(ə)SoSo | by name | <i>Bhatija/Bhatijalora</i> |

| | | |
|-------------------|----------------|--------------------------|
| 10 = FaBr(y)SoDa | by name | <i>Bhati ja-suwali</i> |
| 11 = Fa Br(y)DaSo | by name | <i>Bhagin/Bhaginlora</i> |
| 12 = FaBr(y)DaDa | by name | <i>Bhagin-suwali</i> |
| 13 = FaBr(◊)SoSo | by name | <i>Bhati jalora</i> |
| 14 = FaBr(◊)SoDa | by name | <i>Bhati ja-suwali</i> |
| 15 = FaBr(◊)DaSo | <i>Bhagin</i> | <i>Bhaginlora</i> |
| 16 = FaBr(◊)DaDa | <i>Bhagini</i> | <i>Bhagin-suwali</i> |
| 17 = Z(y)So | <i>Bhagin</i> | <i>Bhaginlora</i> |
| 18 = Z(y)Da | <i>Bhagini</i> | <i>Bhagin-suwali</i> |
| 19 = Z(◊)So | <i>Bhagin</i> | <i>Bhaginlora</i> |
| 20 = Z(◊)SoWi | <i>Bhagini</i> | <i>Bhagin-buwari</i> |
| 21 = Z(◊)Da | <i>Bhagini</i> | <i>Bhagin-suwali</i> |
| 22 = Br(◊)So | by name | <i>Bhati jalora</i> |
| 23 = Br(◊)SoWi | <i>Buwari</i> | <i>Bhati ja-buwari</i> |
| 24 = Br(◊)Da | by name | <i>Bhati ja-suwali</i> |
| 25 = Br(y)So | by name | <i>Bhati jalora</i> |
| 26 = Br(y)Da | by name | <i>Bhati ja-suwali</i> |
| 27 = Br(y)DaHu | <i>Juwai</i> | <i>Bhati ja-juwai</i> |
| 28 = So | by name | <i>Putra/Putek/lora</i> |
| 29 = SoWi | <i>buwari</i> | <i>Putra-buwari</i> |
| 30 = Da | by name | <i>Ji</i> |
| 31 = DaHu | <i>Juwai</i> | <i>Ji-juwai</i> |
| 32 = MoBr(◊)SoSo | by name | <i>Bhati jalora</i> |
| 33 = MoBr(◊)SoDa | by name | <i>Bhati ja-suwali</i> |
| 34 = MoBr(◊)DaSo | <i>Bhagin</i> | <i>Bhaginlora</i> |

| | | |
|------------------|----------------|-----------------------|
| 35 = MoBr(◊)DaDa | <i>Bhagini</i> | <i>Bhagin-suwali</i> |
| 36 = MoBr(y)SoSo | by name | <i>Bhatijalora</i> |
| 37 = MoBr(y)SoDa | by name | <i>Bhatija-suwali</i> |
| 38 = MoBr(y)DaSo | <i>Bhagin</i> | <i>Bhagin-lora</i> |
| 39 = MoBr(y)DaDa | <i>Bhagini</i> | <i>Bhagin-suwali</i> |
| 40 = MoZ(◊)SoSo | by name | <i>Bhatijalora</i> |
| 41 = MoZ(◊)SoDa | by name | <i>Bhatija-suwali</i> |
| 42 = MoZ(◊)DaSo | <i>Bhagin</i> | <i>Bhaginlora</i> |
| 43 = MoZ(◊)DaDa | <i>Bhagini</i> | <i>Bhagin-suwali</i> |
| 44 = MoZ(y)SoSo | by name | <i>Bhatijalora</i> |
| 45 = MoZ(y)SoDa | by name | <i>Bhatija-suwali</i> |
| 46 = MoZ(y)DaSo | <i>Bhagin</i> | <i>Bhaginlora</i> |
| 47 = MoZ(y)DaDa | <i>Bhagini</i> | <i>Bhagin-suwali</i> |
| V/1 = Z(y)SoSo | <i>Nati</i> | <i>Bhagin-nati</i> |
| 2 = Z(y)SoDa | <i>Natini</i> | <i>Bhagin-natini</i> |
| 3 = Br(◊)SoSo | <i>Nati</i> | <i>Bhatija-nati</i> |
| 4 = Br(◊)SoDa | <i>Natini</i> | <i>Bhatija-natini</i> |
| 5 = Br(y)DaSo | <i>Nati</i> | <i>Bhatiji-nati</i> |
| 6 = Br(y)DaDa | <i>Natini</i> | <i>Bhatiji-natini</i> |
| 7 = SoSo | <i>Nati</i> | <i>Putra-nati</i> |
| 8 = SoDa | <i>Natini</i> | <i>Putra-natini</i> |
| 9 = DaSo | <i>Nati</i> | <i>Ji-nati</i> |
| 10 = DaDa | <i>Natini</i> | <i>Ji-natini</i> |

CHAPTER VI :

DISCUSSION

- * The Situation of the Ahoms through History
- * The Contemporary Ahom Situation
- * Generalization

DISCUSSION

So far in our journey through the history of Ahoms to the contemporary Tai-Ahom society in Lakhimpukhuri we have seen Ahoms in two distinct socio-cultural situations :

1. The Ahom situation through history, and
2. The contemporary Ahom situation.

Here, we make an attempt to give a review on continuity and change among the Ahoms in different contact situations.

The Ahom situation through history :

It is an established fact that this great mongoloid Tai-race, the Ahoms, have, when entered Assam in the year 1228 A.D., been a culturally distinct group. Their situation at that point in history must have been somewhat hesitant. They must have been constantly looking for a new home to establish themselves in the alien country. It is also evident from their history that they came along with 9000 men, women and children who belonged to seven clans (*sat-gharia Ahom*. Barua 1978:18). These seven clans with their fellow members formed the foundation of Ahom social organization in Assam.

Gradually, with their skill in the art of wet-rice cultivation (Buragohain 1988:119) they started their first sedentary life at Charaideo in the present district of Sibsagar. For a long time they maintained a ^{low profile} but fought vehemently as and when required.

As seen in our earlier chapters, the group had tried to maintain strict endogamy although at times deviating from this rule by marrying women from outside the group. Clan exogamy was the basic rule of marriage. This is evident from the fact that even among the affluent Ahom commoners who enjoyed special status according to their birth looked only for Ahom boys for their daughters but their sons could marry any women from other groups (Gogoi 1985:99).

This suggested that there was much laxity in the marriage rules on one side, i.e., when one marries in. As long as one avoids one's own clan, there is no breach of marriage rule. This also suggested that such an originally small group had no other choice but to marry outside the group so as to avoid incest.

The above discussions reveal that praxis overrides tradition, or there seems to be an inner conflict of tradition. Tradition as we view :

...as the way society formulates and deals with the basic problems of human existence, therefore, cannot leave a culture to die

out. ... Tradition is, therefore, and has to be bound up with the ever-shifting present (Heesterman 1972:97). Here the patrilinearity of the group becomes prominent and strikes an equilibrium in the Ahom social structure. Hence the Ahoms always looked for a *jatua-Ahom* (Ahom by birth) for their daughters and any woman for their sons.

Nevertheless, the marriage policy of the Ahoms brought about a change in the traditional Ahom society. For instance, Guha observes that :

"Ahoms, Morans, Borahis and Chutiyas had all been undergoing a process of merger into a larger community through free inter-marriages and the ongoing acculturation for so many centuries. In that process all the four tribes had lost their separate identities even before their coming into the fold of Hinduism" (Guha 1983:44. Cited in Buragohain 1988:105)

Although the Ahom society was politically organized into two distinct classes - the ruler and the ruled in course of time new administrative posts were created and officials other than the Ahoms were also recruited. This too brought about a change in the social structure for these members gradually started identifying themselves as Ahoms - a process which Phukan (1968) and Guha (1987) refer to as *Ahomization*. Moreover,

...the centralized authority and feudal type of administration provided the ground to accommodate the culturally diverse groups within a single political (economic) system (Buragohain 1988:107).

Once again the traditional social structure based on seven clans (*Phaid*) got disintegrated due to the centralized administration, and a wide gap between the royal clans and Ahom commoners emerged which of course got filled up with newly inducted officials from other groups. Such a change was eventually justified as 'essential' for a better solidarity and smooth administration of the state. But the conflict remained unresolved, although a 'dynamic-equilibrium (Person 1961) was attained.

Secondly, the Ahom religion was identical with most of the local populations (who were also animist) and that gave an easy access to both the parties to be assimilated. The use of Assamese language as a means of communication made things easier and the then Ahom social system admitted no restrictions or taboos on commensality and connubium (Bhuyan 1962:132) which had made social integration smooth and simple. The 'hydraulic culture' (Buragohain 1988:116) of Ahom society based on feudal administration and control over cultivatable land also brought about a hierarchical interdependence within the Ahom social structure. This brought a functional integration among all the commoners in general, irrespective of caste, creed and community under one category of *paik* forming a *got* and a *khel*. This further stratified the traditional Ahom society internally.

Later the Ahoms came in contact with the Hindus in a dramatic way. It so happened that between the years 1389 and 1397, after the assassination of the king Tyaokhamthi (1380-1389), there was no suitable successor to the throne, and the great nobles ruled the country without a king. Few years later, Thao Cheokan came across a young boy in a Brahmin family at Habung who, on further inquiry, was confirmed to be the son of Tyaokhamthi from his younger queen who was placed on a raft to drift under the orders of the two elder queens for a charge framed against her. The queen was rescued by a Brahmin, when she delivered a son and died (Gait 1984:82).

The boy came to be known as Sudangpha and became the king in 1397. He was also popularly known as Brahmin prince. It was Sudangpha who installed the old Brahmin as his confidential adviser. Under his influence many Hindu rites and ceremonies began to be observed in the palace (ibid:83).

Interestingly at then these Hindu rites and rituals were observed only within the royal palace. The king was not converted into Hinduism, he was merely positively inclined towards Hinduism. The Ahom commoners were least affected by the tenets of Hindu philosophy. Presumably, the

commoners were following the traditional Tai religion as their history is, as usual, silent.

Later, when Susenpha (1439-1488) became the king he too was inclined towards Hinduism and particularly towards the saivic cult. He was perhaps a believer of either *Siva* (a Hindu God) or *Burhagosain* (a kirata God) and constructed a temple dedicated to *Nagashankar* (Gogoi 1985:55).

By then there was an increasing influence of the Brahmins and in 1497 when Suhungmung (1497-1539) became the king, he assumed the Hindu title of *Svarga Narayan*. Since then *Svarga Deva*, a variant of *Svarga Narayan*, became the designation by which the Ahom kings described themselves in their official document (Gait 1984:86). It was during the reign of Sukhampha (1552-1603) that the Ahom king for the first time started consulting Hindu astrologers along with their own Deodhai-Bailung. It is recorded in the history that during the famous Saraighat war, cannons were fired only at the time stipulated by the Hindu astrologers (Gogoi 1985:99).

Hindu influence got more intensified during the reign of Pratap Singha (1603-1641). He came to be known as *Buddhi-Svarga-Narayan Pratap Singha*. It was Pratap Singha who brought about a revolutionary change in Ahom diplomatic

structure by installing 13 Brahmin families as diplomats. It was Pratap Singha again who on the advice of Brahman pundits released two gold coins as Buddhi-Svaraga-Narayan and Svarga-narayan respectively. Sakti in the form of Durga (Mother Goddess) came to be propitiated in the royal family during his reign.

So far we have observed that religious affiliation of the kings coupled with the installation of non-Ahoms to certain key posts in administrative structure apparently did not influence the social life of the Ahom commoners, but at the same time it had, for sure, an impact on traditional Ahom social structure. For instance, official rank, responsibilities, were mostly according to one's birth in a particular Ahom clan. The entry of non-Ahoms to these posts which were hitherto hereditary further stratified the Ahom society. This also paved the way for the dilution of clan based Ahom society to the lineage based one (which we shall deal with later). The strength of this statement lies on the 'assumption' that perhaps the hierarchical and functional interdependence that operated within the seven clans of the Ahoms was gradually becoming weak. Moreover, the establishment of new *khels* and reorganization of villages dispersed the Ahom commoners to the new villages along with other non-Ahoms which resulted in a heterogeneous village community.

By then, the Neo-Vaisnavism of Sankaradeva was gaining much strength and popularity among the masses in spite of much restrictions imposed by the Ahom court. It was during the reign of Sukhapha (1552-1603) and Pratap Singha (1603-1641) that a large majority of Sankaradeva's disciples got divided into the four *Samhatis* and a number of *Satras* came into being. The erstwhile concept - "King's religion is the citizen's religion" started diluting.

Yet another contact situation emerged when Sankaradeva's Neo-Vaisnavism under four *Samhatis* started getting royal patronage. Jayadbhvaj Singha (1641-1644) was the first king to be initiated to a Vaisnavism. He started the official rule of issuing *Devottor*-land grant to the *satras* by inscribing on a copper plate. The king got so engrossed in his newly adapted religious philosophy that when Mirjumla took the Ahom capital Garhgaon by surprise, a fisher-woman was reported to have told him that if, for the last twenty years, the king had cared to pile twenty lumps of earth, he could have raised a barricade big enough to resist the Muhammadans (Gogoi 1985:56). This was clearly a sense of discontentment among the commoners created by the negligence of the king towards the affairs of the state. The Ahom priestly clans, Deodhai-Bailungs were equally offended.

Likewise, from Udyaditya Singh (1669-1673) to Sulikpha (1678-1681), all the kings were the disciples of one *Satra* or the other. Gradually, besides the royal clans, the Ahom commoners started getting initiated into Vaisnavism. This marked the beginning of a conscious change in traditional Tai-Ahom beliefs and practices. Although until the reign of Gadadhar Singh (1681-1696) both the royal families and the commoners openly followed dual religious practices - the traditional Tai-Ahom practices and the Neo-vaisnavism. This further divided the Ahoms into four endogamous groups based on their religious affiliation to *Brahma*, *Kala*, *Nika*, and *Purusha-samhatis*.

The contemporary Ahom Situation :

So far we have examined the possible historical contact situations that brought about the process of acculturation among the Tai-Ahoms of Assam in a wider perspective. In the following discussion, we shall try to narrow down our discussion on acculturation and focus it on the village Lakhimpukhuri in an attempt to examine the impact of those historical processes from the contemporary perspective.

The village has experienced all the above mentioned historical forces in the past (see chapter IV) and

the present day situation in the village is the cumulative result of all those forces.

The present population of 468 members with 75 households are the descendants of 15 original households (genealogies attached in appendix) which were established after the Mayamoria Rebellion in 1782, during the reign of Gaurinath Singh (1780-1795) for agricultural purposes. Thus the village community began as a single functional unit although the group was already divided according to their adherence to different sects of Vaisnavism.

Today the village is divided into two religious orders - *Brahma-Samhati* and *Kala-Samhati*, each affiliated to two different *Satras* - Dakhinpat and Bareghar *Satra* respectively.

Within the village, a villager relates himself to several classes of kinsmen beyond his immediate families. His most frequent interaction is usually with those families close to him in patrilineal descent and in residence, a group that may be called a 'localized lineage' (Mandelbaum 1970:134). The men are brothers who have set up separate households or the sons of brothers or patrilateral cousins. All the members in these households, including wives and

children, are considered part of the group even though they are of different patrilineal descent from the related men.

There are 15 such **localized lineages** with a maximum of 16 households in one and a minimum of 1 household in several others (in chapter IV, we have presented them as descent groups).

Due to the wide dispersal of the erstwhile clans throughout Assam today this **localized lineage** remains as the strength of the group. The families belonging to one such **localized lineage** usually perform formal ritual functions together, especially in observance of mourning. Even those families of such **localized lineage** who happen to reside outside the village for certain reasons like occupation or 'preferential' settlement in other towns or cities, are equally affected by such ritual pollution. Such a lineage may be regarded as an extension of the family and hence it is exogamous. It may also be termed as 'effective-lineage' (Mayer 1960), or *bamsha-parial* in Lakhimpukhuri. The spatial compactness of this group is maintained by inheritance of family property.

The role played by the **localized lineage** brings about a functional integration within the group and

also helps to define the boundaries of the group. Interestingly enough, in such a group even certain rituals reinforce the sense of WE feeling within the group and that definitely stabilizes the identity of the group within a changed environment. This suggests that among any groups, no matter how much a group undergoes changes, it always tries at a certain level to set a limit to such changes and thereby maintains a functional integrity within itself. The figure below is an attempt to explain the structural consistency of the Ahom society :

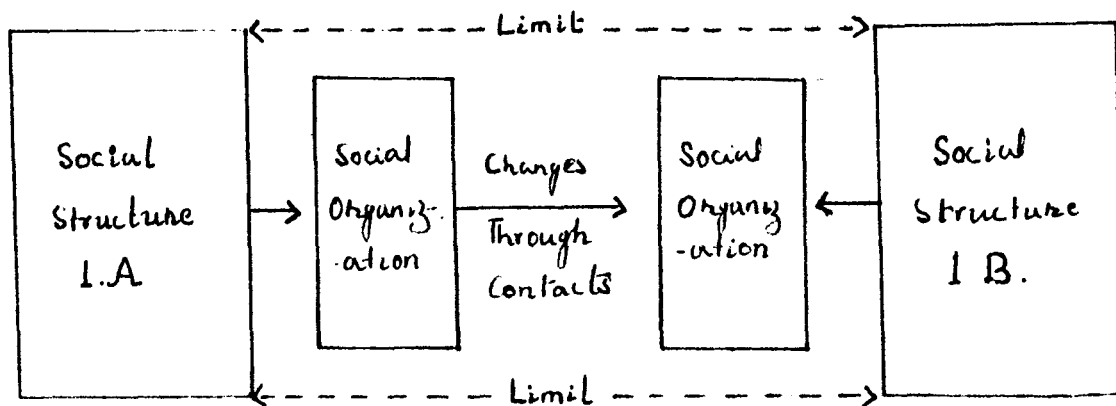

Fig. VII : The Ahom social structure.

If we accept social structure as an abstract or a model representing what one ought to be and social organization as what one really is (Firth 1954:5), we find that in a society individuals are organized in the light of its social structure. Both social structure and social organization are complementary to each other. Praxis do not necessarily tally the ideal and within the social organization activities are thus regulated according to the need of the

society. Any departure from the ideal does not effect the structure as long as it is within the limit. Only those departures that exceed the limit set by the structure and are permanent, can bring about a structural change (Firth 1954:4).

Carrying the above argument we can say that in the figure VII. as long as the social organization does not exceed the limit, the social structure IB is a mirror image of IA; and the identity of the group persists. Similarly in case of the Ahoms, 1). 'assimilation' of the autocthones enlarged the Ahom social organization (through regulated marriage, selective adaptation of cultural traits, etc.). It was necessary for a definite purpose relating to production relation system and administration (administration of the people with varied culture) and also it consolidated the strength of the Ahom social structure in terms of social, economic and political power.

2). Owing to the spatial dispersal of the clans, formation of the 'localized lineage' replaced the role of clans to a large extent. Sapinda rule gave a similar recognition to the 'localized lineage' as enjoyed by the earstwhile clans.

3). All these changes occurred in conformation, not in deviance to the Ahom traditional social

structure which actually gave a stability to the structure.

Beyond his village, a villager has another social network known as *mitir* (feminal kins. Mandelbaum 1970:148). *Mitir* are the relations of a man through his mother, his married sisters, his married brothers, his wife, his married daughters and married sons. This group provides an emotional support to a man, standing in a number of relations to him, as and when necessary; and the extent of closeness depends on how much frequent contact that one can maintain with one another.

Among the *mitir*, mother's brother is a special supportive kinsman. At times he and his household members become the only source of help when every other kinsman withdraws. Perhaps due to his sentiments attached to his mother's brother, he can freely express his feelings to the maternal uncle. It is also the mother's brother who, along with other lineal relatives, has the right to offer a special *xarai*-full of gifts (sweets and some money) known as *mamai-gharia-xarai* (*Xarai* from mother's brother's family) to the group of women from the village who sing at the marriage of his sister's children. This is a right not mandatory on other *mitir*.

Today, due to one's marriage to persons at distant places, *mitir* are not often sighted in the village, except in certain occasion of life-cycle ceremonies if called for. It is also owing to the fact that every time new *mitir* are established and the old ones become less effective due to lack of 'reference-person' (person through whom a *mitir* is established).

Nevertheless, *mitir* enjoy a special treatment of love and affection which one may not find amongst the lineal relatives, who unlike the *mitir*, have a claim on economic asset of the group, mainly land. They also form an important linkage for expanding one's *mitir* with new families. In other words, *mitir* give an external support to the group and also help in the internal growth of the group.

Within the village again, it represents a dual social network. In our earlier chapter(Chapter-III) we have seen how neo-vaishnavism has brought about a division in the Ahom society. Impact of that historical process is clearly visible in this village. Administratively, the village is a single unit under one *gaon-burha* (Village headman) appointed by the government. But, on the other hand, within the village, the villagers are divided into two religious divisions - *Brahma-samhati* and *Kala-samhati* (see

chapter III) and has two separate *nam-ghar* respectively. Forty one households out of the total seventyfive are adherent to *Kala-samhati* and the remaining thirtyfour households are the believers in *Brahma-samhati*.

Initially these divisions have been very distinct and the members maintained strict commensality and connubium (see chapter IV), although a number of inter-*khel* marriages have taken place in the recent past. Out of a total twelve such marriages, seven females have come to the *Brahma-samhati* sect and five females have gone to the *Kala-samhati* sect. All these marriages have taken place by elopement. They are not 'socially desirable' according to the villagers.

Our discussion in the previous section showed how freely the Ahoms use to chose their consort maintaining the rule of *jatua-Ahom* for their daughters only, and gradually becoming selectively endogamous within their own *samhati*. Today, they have broken this rule by 'undesirably' marrying Ahoms from different religious sects. Although, the society does not encourage such marriages, it does not have any rigid social sanction against such marriages today. Rather it has developed a smooth mechanism of tolerating such incidence by giving social approval to such union. The

process of 'initiation' as given by the *satra* to initiate any such person into the group can be seen as a force to stabilize the group. Over and again, through our discussion we observe that any event that tries to destabilize the group gets subdued by some mechanism or the other in order to maintain the structural integrity of the group. One may not get an effective *afinal* *kins* or *mitir* from such union. Nevertheless, one adds a new member to one's group. Moreover, it is from within the accultured culture that one tries to find such adaptive mechanism to maintain the group solidarity.

Commensality, as seen today, is restricted to those who are old and initiated. Younger generation Ahoms seem to care the least about it. In fact, in a certain festive occasion, young members from *khel-A* openly participated and ate pork or drink rice beer in *khel-B* which were once considered *akhadya* (see chapter IV) in *khel-A*. Some even cooked pork at their own place outside the *majia* (see chapter IV).

Today rice beer may be fermented in *khel-B* and secretly be brought and consumed in *khel-A*. One may also freely enjoy his bottle of distilled liquor which is sold in the village fair-price shop in *khel-A*. India manufactured foreign liquor, otherwise, is consumed without any prejudices.

They say "it is good but costly" and is reserved for special occasions like festivals, a visit of a *mitir* etc. The younger generation tries to rationalize such habits by saying that "our ancestors used to eat and drink anything under the sky and why should we not?". At times they seem to despise their being Vaisnavite and say "religion is for the old and the initiated; we will think about it when time comes".

Such an attitude of the younger generation visibly gives us two trends of change within the group in Lakhimpukhuri, although it is too early to comment on them. But it can not be overlooked either. Firstly, the active membership to the *nam-ghars* and thereby to the *satras* is gradually decreasing. Secondly, the dividing line between the two religious sects within the village is getting thinner and thinner and alcoholism in *khel-A* is becoming a threat to the family stability. There is also another trend in the village which is evident from their conscious attempt to know and perform certain traditional Tai-Ahom rituals. What prompts them to do so is a subject of further study.

On examining the traditional Tai-Ahom and present day Hinduized beliefs and practices, we find similarity in a number of such beliefs. Differences may occur in the way of performing the associated rituals, i.e. the

forms. Presence of such similarity may suggest a much early exposure of the group to Hinduism. This aspect of 'exposure' to Hinduism can not be ruled out totally because "...in

South-East-Asia Hinduism was predominant in those days. This was partly due to the efforts of Hindu colonists and partly due to commercial intercourse between India and the South-East-Asian countries (The Imperial Gazetteer Of India Vol.IX. 1908:107. Cited in Sen 1982:53); and "...Indian alphabet Dev Nagri was used in Tai-language up to the thirteenth century A.D. in Thailand and its neighbourhood (Mazumdar 1968:261. cited in Sen 1982:53).

If this is so, then Hinduism and later impact of Buddhism in South-East-Asia had undoubtedly set on the process of acculturation of the Ahoms even before they migrated to Assam. Later influence of Buddhism in South-East-Asia is very much evident from their Tai-script and other humanitarian activities which they undertook like construction of roads, digging of large ponds and building of temples on the banks of these ponds (Gogoi 1985:58).

Acculturation is a historically established phenomenon. It is also well established that one of the ways that cultures have grown is through borrowing. But the most interesting and at the same time challenging aspect is the selective borrowing and converting the borrowed items in such a manner that they fit into the culture of the borrower. It may continuously go through a process of fine tuning. On this when we superimpose the economic and political compulsions a

group has to confront, the acculturation process becomes highly complex.

The contemporary beliefs and practices in Lakhimpukhuri appear to be dominated by the Hinduism. This is not surprising because the people claim themselves to be the Hindu. But they are The Hindu with a difference. They have a non-Hindu history which is pretty well known through a variety of popular media. They have a history of which people are proud of. It is not something which they would obliterate from their memory. Thus it could be hypothesised that a group like the Tai-Ahoms would be very selective in adaptation. Our data support this hypothesis. It is observed from our data on Lakhimpukhuri that those beliefs which have similar connotation in other culture get readily accepted. So is the case with the practices which the receiving culture finds similar utility value in it. Even myths which are similar get superimposed on the myths of other culture. For instance, the origin myth of the Ahoms that they are the descendants of Lengdon, the lord of heaven, has led to the creation of a new myth that facilitated the acceptance of Indra as synonymous to Lengdon and thereby accepting the kshatriya status with a lineage of *Indra vamsiya* (Gogoi 1968) and the title - *svarga-narayana* and *svargadeva*. So is in the case of *kecaikhati* and *ranachandi* among the Dimasas (Bhattacharjee

1987) and thereby gaining admittance to Hinduism. Situation of the Dimasas changed after they were forced out of their kingdom and only a section of them remained Hindu much after they were initiated through *saran-bhajan* process of the *satra*, and today they are known as *Sonowal Kachari* in upper Assam. The Meiteis, however present a very different situation in this context in the sense that the king Garibnawaz had forced the Meities to take an oath that they would not negate the practices of Hinduism in the year of 1729 (Arunkumar 1993:143-44).

Similarly, a number of other tribal groups in Assam adapted Hindu *acaras* (ways of life) "...through giving up former habits and customs, such as eating pork and other forbidden food and drinking strong liquor; undergoing *prayachit* (atonement); and receiving *saran bhajan* from a *Gosain*, could gain admittance into the Hindu society with the status of *Saru Koch* (low Koch). For the first three generations they were looked down upon a little by their Hindu comrades and they were not allowed to take any leading part of their society. From the third generation they were accepted quite good as any Hindu of the *Bor Koch* (High Koch) caste (Bhagabati 1992:490).

Coming back to the beliefs practice, the Ahoms readily accepted those Hindu *Samaskaras* which are similar to their own. They accepted some to emulate or to achieve certain goals - upward mobility on caste hierarchy. But in the course of time, some were discarded when their purpose was fulfilled and their utility value had diminished.

The Vaisnavas in Assam perform *Smārta* rites in accordance with the prescription of *Dharmasāstras*. The Vaisnavas belonging to backward classes and tribes, however, do not uniformly perform these *sāmaskāras* (Sarma 1966:119). The Hindu scripture *Jatukaranya* as quoted in *Sam.Pr* (P.135) enumerates sixteen *sāmaskāras* as *garbhadhana*, *pumsavana*, *caula*, *maunji* (*upanayana*), *vratas* (four), *godana*, *samavartana*, *vivaha*, and *antyeshti* (cited in Kane 1974:194). Gaut (VIII.14-24) speaks of forty *sāmaskāras* (Kane 1974:193).

It will be pointless to discuss the *sāmaskāras* from the *Dharmasāstras* in detail as there is no single authority on it. There is a great divergence of view among the writers as to the number of *sāmaskāras* themselves (Kane 1974:193). Therefore, we shall try to present those similar beliefs and practices as observed in this village and also certain others which have been either modified and incorporated or adapted according to the local niche.

To begin with, we present our data related to the life cycle of a man as observed in Lakhimpukhuri. Birth, as seen in chapter IV, is not simply a biological phenomenon of conception, pregnancy and delivery. These are enveloped in sociological process that entails a series of socio-religious beliefs and practices.

The prescribed traditional Hindu *sāmaskāras* like *garbhadhana* and *pumsavana* are visibly absent among the group, as they are meant specifically for the *dviija* or the twice-born caste Hindus. *Sāmaskāras* after conception like *garbharaksana/anulobhana* can be equated with *pitha-khowa* which is prevalent in the village with certain modifications. It is performed on the first month of pregnancy unlike on the 4th month of pregnancy as prescribed in *smṛtyarthasāra*, with rituals modified according to local resources. This is a ritual which may have been adapted to identify the group at par with the neighbouring Hindu population. This particular ritual, in an institutionalized form is absent in the traditional Tai-Ahom culture. Of course, certain taboos that they follow may be equated with this ritual.

Panchamrit-khowa, is another ritual performed in the village. It is perhaps an extension of *garbharaksana* or may be equated to *sasyantikarma* which, among the traditional Hindus, is performed on the 10th month of pregnancy. In this village, it is performed in the wife's natal home on the 5th or 7th month to gain strength and vitality for the growing foetus. *Sasyantikarma*, otherwise, is a rite for a woman who is about to deliver a child (Kane 1974:227).

Jatakarma, the Hindu ritual performed in the case of birth of a son, is formally absent among the Ahoms in this village. But there is a practice of distributing fish, especially large scaled fish when a couple is blessed with a son. Even this ritual seems to be an adaptation from the local niche, and can be seen only among those who can afford it. In the village, the practice under question has become completely redundant today.

Homa/sūtikagni (it is prepared by placing the broken piece of a jar on the fire-place and heating it with the dried dung of a bull) is established near the door of the lying-in chamber of the lady who has delivered a child. White mustard seeds and rice chaff are to be offered in the fire for ten days whenever any body enters there.

Similar practice of establishing a fire near the bed of the mother and child, after delivery, is seen in the village. This practice is known in Tai as *uufai* and is devoid of any rituals but it is meant for 'drying-up' of the abdomen of the woman who has delivered a child. There is no stipulated number of days for the fire to be kept on. Associated with this practice is of course a ritual partaking of special food called *jaal-diya* which is performed on the 3rd day after child birth.

Namakarana or naming a child is a practice which is invariably present among all the Hindu communities. Traditionally, among the Ahoms, a child was given a name by a priest (see chapter IV). After they have embraced Hinduism, names of Hindu gods with certain suffix, names of legendary figures, names of flowers etc. are given to a child on the first day. These names are usually prescribed by a Brahmin priest after certain astrological calculations. At times, out of fear lest the child does not die or fall sick, funny names may also be given in an attempt to ward off the evil eye (see chapter IV). But no strict rules of avoidance or rejection of certain names as prescribed in Dharmasastra are followed.

Niskramana is a ritual of taking the child out of the house or in the open for the first time. A number of rituals are associated with it. A strong resemblance of this traditional Hindu ritual can be drawn with similar objective of introducing the child to the world, from the traditional Tai ritual called *aw-ook-can* or *baaj ulua* (in Assamese) as found in the village Lakhimpukhuri. It has also been adapted by other Assamese groups at large.

Annaprasana, or *Hudi* as it is known in the village, is undoubtedly an Assamese version of *annaprasana* which the Ahoms have adapted. It is performed when the child

is of 6 months old. It is absent among other Assamese Tai. The indispensable role of the mother's brother, *mama*, is a new element added to the traditional Hindu ritual prescribed in Dharmasastra, and is prominent in Orissa, Bengal and Assam. Introduction of *mama* into the ritual may perhaps be seen as a symbolic acknowledgement of material support that he is expected to provide to his sister's family, and is well evident from the earlier ritual *jaal-diya* performed on the 3rd day of birth, where the main provisions for the special dish are to be provided by him.

This ritual is seen today only among those who can afford it. Most of the villagers have either do not observe the ritual or do not even remember having performed this ritual at all.

Cudakarma or the first hair shaving ritual is prominent among the western Tai groups and is believed to be due to 'Indianization' of the groups by the 'Indianized' peoples with whom the Tai who trekked westwards came into contact and that it does not belong to the ancient Tai culture of the first millennium A.D. (Terwiel 1980:39). Therefore, it can be seen as a continuation of that 'Indianized' practice (ibid) which has found a similar meaning among the Hinduized Ahoms. The ritual again has become redundant and is seen completely out of practice in this village.

Nua-tuloni-biya is a ritual which is typical of and unique to the Hinduized Tai Ahoms and many other Assamese groups. The very nature and the objective of this ritual seem to be contradictory to the prescription of *vivaha* in the Dharmasastra. According to the prescription of Dharmasastra, unmarried daughters at their natal home, after attaining menarchy, incur sin to their parents and brothers (Kane 1974:444); while in *nua-tuloni-biya*, it is an open exhibition of their daughters at the age at menarche. Perhaps the ritual of mock marriage with a banana tree is a symbolic atonement achieved by the parents by marrying off the daughters, when the actual marriages take place much after, when suitable grooms are found. This is an example of innovation of culture trait to fit into the central theme of the religion that they have adapted.

The ritual today is not universally observed in every household as discussed in chapter IV, yet it seems to be a 'die-hard' practice because of the concept of purity and pollution attached to it. Therefore, if not for oneself, it is more important to perform this ritual for the sake of saving the family from the clutch of disgrace and humiliations if one fails to observe the minimum expected ritual.

Of late, this ritual is taking a different turn. Among those who can afford, the last rite of purification, i.e., on the 11th day (the duration may also be cut short to 9 days), is performed with full splendour and it resembles an actual marriage. Today, men folks openly participate in the ritual by drinking and playing cards for the rest of the night. Men's participation otherwise was a sort of taboo in this ritual.

Vivaha/udvāha/panigrahana or *biya* as discussed in our chapter IV:B gives us an idea as to how the Ahoms maintained a strict clan exogamy in the historical past. Because of the wide dispersal of the clans with the expansion of the state, the marriageable clans became inaccessible. Then with the acceptance of Hinduism, clan exogamy transformed into 'lineage exogamy' on the basis of *sapinda*-rule (restriction of marriage within the prohibited degrees. Kane 1974:438). *Sapinda* means 'one who is connected with another through oblation of food'. Food here is the *pinda*, 'the ball of rice' that is offered in *śrāddhas* to ancestors (Kane 1974:472). The rule prohibits one's marriage with a person standing up to 7 generations from the father's side and 5 generations from the mother's side. The practice of maintaining *vamsavali* among the Ahoms perhaps facilitated the acceptance of this rule under the changed socio-religious

environment. Even today, *sapinda*-rule is followed while selecting a mate. Also marriage outside the group is not uncommon.

As far as the ceremonial aspect of marriage is concerned, the Vaisnavas in Assam (including the Ahoms) follow the practice of *sampradana* (formal release of the daughter by one of the parents) after *katha-bujoni* (a short lesson on the rights and duties on marriage based on Dharmasastra, imparted by the eldest member among the invited *Bhakats*). *Agnisthapana* and *homa* are completely absent in this ritual, while it is present amongst other Assamese groups.

Chaklang is the traditional Tai-Ahom marriage ritual in which *katha-bujoni* (see chapter IV) is also imparted in Tai language which is later translated into Assamese. Interestingly, the Assamese version of it resembles the *katha-bujoni* of the Vaisnavas based on Dharmasastras. It is perhaps for this similarity and for the cost involved in *chaklang* ritual that the Hinduized Ahoms have accepted the *katha-bujoni* way of marriage at large. The *chaklang* ritual which is practised today even carries a number of the Hindu traits, viz., the application of vermilion on the forehead of the bride and the act of the exchange of garland. In the

present village where only one such *chaklang* marriage has been recorded after 30 years, where even the Ahom villagers from the nearby villages, invited or uninvited came rushing to witness *chaklang*. The incident is undoubtedly a state of renewed interest of the people to know more about the ritual.

Antyesti, the last rite related to a human life, is performed in three different phases, viz., *tiloni*, *daha* and *mahekia-hakam* (see chapter IV:B). These rituals in the village represent a mixture of Vaisnavite, Hindu-sapinda and Tai rituals. All these rituals concern with the dead and the ancestors. The belief in ancestors among the Ahoms has been the central theme of their ancient religion (as evident from community rituals like *me-dam me-phi* and *umfra*). This strong belief on the souls of the dead perhaps facilitated the acceptance of those Hindu rituals which are related to death.

Besides these special life-cycle rituals, there is another important ritual *snāna*, which is prescribed in the *Dharmaśāstra* (Kane 1974:664-67). These ritual-bathings or *snana* have been selectively accepted by the Ahoms and they do have a similar concept of *aptāng* (ceremonial bath) within a larger purview of *rik-khvan-mung-khvan* with the primary objective of gaining strength and vitality (see

chapter IV). This ritual can be seen in the light of *kāmya-snāna* (bath for some desired object) as prescribed in Dharmasastra (Kane 1974:666).

An Over-view :

Some 700 years back, in the year 1228, a small group of adventurous people, with their chief Sukapha entered Assam with little knowledge of the fact that they would be arrested forever by the banks of the mighty Brahmaputra. In course of time, they set the foundation of a nation - Assam and a new nationality called Assamese emerged.

While doing so, the group ungrudgingly accepted the ethos and values of the soil, leaving "some of their own" and equally contributing "some of theirs" to the local population. Now, 700 years after, the group stands proudly as the genitor of the culture the Assamese.

Even when they have undergone a tremendous change in every sphere of life, they seem to have set a limit to the forces of change and zealously guard their identity of being an Ahom within the greater identity, i.e., the Assamese.

Certain new elements are incorporated into the group by a selection-elimination process with a definite

purpose of maintaining their identity. The historical forces that operated on the Ahoms of the Lakhimpukhuri village were similar to all the Ahoms of Assam. Therefore from our discourse on the acculturation of the Ahoms, we may forward a few generalizations as to show how the process of selection-elimination operated under a number of contact situations that the Ahoms undergoing acculturation had to face. They are as follows :

1. Certain forms are borrowed and incorporated to achieve a higher status in wider social framework.
2. Those values which were similar to their's got incorporated without much change in the original forms.
3. New forms with similar values showed considerable ability of persistence.
4. Certain values got discarded in course of time as they lost utility value in their society.
5. The incoming culture possessed certain vested interests which actually encourage the retention of traditional beliefs of the receiving culture.

On the basis of the above generalizations we may draw this inference that the Ahoms in course of their long history have synthesised a new culture based on the process of acceptance, rejection, and persistence. The new form that has been synthesised shows the persistence of old values to a remarkable degree. This inference validitates our hypothesis.

ERU, LIBRARY

Acc. No. 102838

Acc. by S. P. Talwar

Date 15/1/97

Class

Subject

Ex. No.

Price

BIBLIOGRAPHY

- Arunkumar, M.C. Towards hypotheses to the decline of the Meitei kingdom. *Proceedings of NEIHA*, 13th session. Shillong :Dept. of History, NEHU, 1993.
- Barua, A. Religious outlook of the Ahoms. *Proceedings of NEIHA*, 10th session. Shillong : Dept. of History, NEHU, 1989.
- The Ahom Navy. *Proceedings of NEIHA*, 13th session. Shillong : Dept. of History, NEHU, 1993.
- Barua, G.C. *Ahom Buranji*. Calcutta : Baptist Mission Press, 1930.
- Barua, I. *Social Relations In An Ahom Village*. New Delhi : Sterling Publishers, 1978.
- Barua, K.L. *An Early History Of Kamrup*, 2d Edition. Gauhati : LBS Publications, 1966.
- Bhagabati, A.C. Tribal transformation in Assam and North eastern India : An appraisal of emerging ideological dimensions. B.Chaudhuri (ed), *Tribal transformation In India*, Vol.III. New Delhi : Inter-India Publications,1992.
- Bhattacharjee, J.B. Dimasa state formation in Cachar. S. Sinha (ed), *Tribal Politics And State Systems In Pre-colonial North-east India*. Calcutta : K.P. Bagchi, 1987.
- Bhuyan, S.K. *Deodhai Assam Buranji*. Gauhati : Department of Historical and Antiquarian Studies, 1962.

Boas, F. The Growth of Indian Mythologies : A Study Based Upon the Growth of the Mythologies of the North Pacific Coast. *Journal of American Folklore* 9:1-11. 1896.

Borgohain, J. *Asomar Sansritic Itihas*. Jorhat : Navin Pustakalay, 1989.

Buragohain, R. *Ahom State Formation In Assam : An Inquiry into the factors of polity formation in mediaeval North-east India*. Unpublished Ph.D. thesis, NEHU, 1988.

----- Tai-Ahom state formation : Role of conquest and irrigation in the origin of the Tai-Ahom state. *Proceedings of NEIHA*, 5th session. Shillong : Dept. of History, NEHU, 1984.

----- Social stratifications in the Ahom state formation. *Proceedings of NEIHA*, 7th session. Shillong : Dept. of History, NEHU, 1986.

----- On Brahminical influence in the formation of the Ahom state. *Proceedings of NEIHA*, 8th session. Shillong : Dept. of History, NEHU, 1987.

----- Formation of the Ahom state : The origin and growth of the Pyke system and Ahom feudalism in mediaeval Assam. *Proceedings of NEIHA*, 9th session. Shillong : Dept. of History, NEHU, 1988.

----- Emergence of the Tai-Ahom state in the early mediaeval Assam (1228-1401) : In search of some South east Asian roots. *Proceedings of NEIHA*, 13th session. Shillong : Dept. of History, NEHU, 1993.

-
- Buragohain, R. Integration and inter-ethnic relations in the Ahom state of mediaeval Assam. *Proceedings of NEIHA*, 14th session. Shillong : Dept. of History, NEHU, 1994.
- Carstairs, G.M. *The Twice Born : A Study Of A Community Of High Caste Hindus*. London : The Hogarth Press, 1957.
- Chatterjee, S.K. *Kirāta-Jana-Kṛti, The Indo-Mongoloids : Their contribution To The History And Culture Of India*. Calcutta : Royal Asiatic Society Of Bengal, 1951.
- Chowdhury, P.C. *The History Of Civilization Of The People Of Assam To The Twelfth Century A.D.* Gauhati : Department of Historical and Antiquarian Studies, 1966.
- Devi, L. *Ahom Tribal Relations : A Political Study*. Gauhati : Assam book Depot, 1968.
- Dumont, L. *Homo Hierarchicus : The Caste system and its implications*. New Delhi : Oxford University Press, 1980.
- Dutta, S. The Moran state formation in Assam. *Proceedings of NEIHA*, 5th session. Shillong : Dept. of History, NEHU, 1983.
- Ehrenreich, P. *Dre Mythen und Legenden der Sidamerikanischen Urvölker und ihre Beziehungen zu denen Nordamerikas und der alten Welt*. Zeitschrift Für Ethnologie, Vol.37, Suppliment. Berlin : Asher, 1905.

Firth, R. Social Organization and Social Change. *The Journal Of The Royal Anthropological Institute Of Great Britain and Ireland*. Vol.84, Part I. London :RAIGBI, 1954.

-----..Some Principles of Social Organization. *The Journal Of The Royal Anthropological Institute Of Great Britain and Ireland*. Vol.85, Part I & II. London : RAIGBI, 1955.

Gait, E. *A History Of Assam*. Delhi : Cine Tarika Publications, 1926/1984.

Gogoi, L. *Ahom Jati aru Assamiya Sanskriti*. Sibsagar : Jeuti Prakashan, 1961.

----- *Tai Sanskritir Rooprekha*. Calcutta : Shri Bhum Publishing Co., 1985.

Gogoi, P. *The Tai and The Tai kingdoms*. Gauhati : Dept. of Publications, Gauhati University, 1968.

----- *Tai Ahom Religion And Custom*. Gauhati : Publication Board, 1976.

Guha, A. The Ahom Political systems : An inquiry into the state formation process in madaieval Assam (1228-1714). S. Sinha (ed), *Tribal Politics And State Systems In Pre-colonial North-eastern India*. Calcutta : K.P. Bagchi, 1987.

----- The decline of the Ahom kingdom of Assam (1765-1826). *Proceedings of NEIHA*, 8th session. Shillong : Dept. of History, NEHU, 1987.

- Heesterman, J.C. India and the inner conflict of tradition. S.N. Eisenstadt (ed), *Post Traditional Societies*. New York : W.W. Norton & Company. INC., 1972.
- Herskovits, M. J. African Gods and Catholic Saints in New World Negro Beliefs. Lessa, W.A. and Vogt, E.J. (eds), *Reader in Comparative Religion : An Anthropological Approach*, 2d ed. New York : Harper, 1937/1965.
- The significance of the study of acculturation for Anthropology. *American Anthropologist*, Vol. 39, No.2, April-June, 1937.
- Some comments on the study of cultural contact. *American Anthropologist*, Vol.43, No.1, January-March, 1941.
- *Cultural Dynamics*. New York : A A. Knopf, 1964.
- Homes, W.H. Pottery of the Ancient Pueblos. U.S. Bureau of American Ethnology, *Fourth Annual Report*, 1882-1883. Washington : Smithsonian Institution, 1886.
- Kakati, B. *Mother Goddess Kāmākhyā*. Gauhati : LBS Publications, 1948.
- Kane, P.V. *History Of Dharmasastra : Ancient and Mediaeval Religious and Civil laws*. Vol.II, Part-I, 2d edition. Poona : Bhandarkar Oriental Research Institute, 1974.
- Keye, C.F. Tug of war for merit : Cremation of a senior monk. *Journal of the Siam society*, vol.63.Pt.1.pp.44-62, 1975.

- Koseet, S. (alias Rajadhan Phya Anuman) *Prapheeni Kao Khong Thai*. Bangkok : Prae Pittaya, 1959.
- Krickeberg, W. Die Völker des Ostens und Südostens, Vol.1. pp. 97-112. G. Buschan (ed), *Illustrierte Völkerkunde*. Stuttgart (Germany) : Strecker, 1910/1922.
- Kroeber, A.L. *Cultural Anthropology*. Calcutta : Oxford & IBH Publishing Co., 1948/1972, pp.428-29.
- Le May, R.S. (translator) The Lü , *Journal of Siam society*, Vol.XIX.Pt.3.pp.159-70 (Thai-text.pp.171-86), 1925.
- Lesser, A. *The Pownee Ghost Dance Hand Game : A Study of Culture Change*. Columbia University Contributions to Anthropology, Vol.16. New York : Columbia Univ. Press, 1933.
- Lowie, R.H. *The Crow Indians*. New York : Rinehart, 1935/1956.
- Mandelbaum, D.G. *Society In India*. Bombay : Popular Prakashan, 1970.
- McGee, W.J. Piratical Acculturation. *Selected Papers from the American Anthropologist*, 1888-1920. Evanston III : P. Row, 1898/1960.
- Mead, M. *The Changing culture of an Indian Tribe*. Columbia University Contributions to Anthropology, Vol.15. New York : Columbia Univ. Press, 1932.
- Milne, L. *Shans At home*. New York : Paragon Book Reprint, 1970.

- Mumtaza Khatun, I.S. The marriage relations of the Ahom rulers with the neighbouring ruling families. *Proceedings of NEIHA*, 2nd session. Shillong : Dept. of History, NEHU, 1981.
- Parsons, T. An outline of the social system. T. Parson *et al* (eds), *Theories Of Society*. Vol.I. New York : Free Press of Glencoe, 1961.
- Phukan, J.N. *Lik-Phan-Tai*. Gauhati : Congress Press, 1968.
- Phukan, K.C. Organization of the villages under the Ahom rule. *Proceedings of NEIHA*, 10th session. Shillong : Dept. of History, NEHU, 1989.
- Redfield, R. The Material Culture of Spanish-Indian Mexico. *American Anthropologist* New Series 31:602-618. 1929.
- Redfield, R., Linton, R., and Herskovits, M.J. Memorandum for the Study of Acculturation. *American Anthropologist*, Vol.38, pp.149-52, 1936.
- Schapera, I.(ed). *Western Civilization and the Natives of South Africa : Studies in Culture Contact*. London : Routledge, 1934.
- Seligman, B.Z. *Notes And Queries On Anthrpology*. London : Routledge & Kegan Paul Ltd., 1874/1951.
- Sen, D. Early history of the Tai Ahoms. *Proceedings of NEIHA*, 3rd session. Shillong : Dept. of History, NEHU, 1982.

-
- Sen, D. Bodo-Ahom relations (1200-1526 A.D.). *Proceedings of NEIHA*, 4th session. Shillong : Department of History, NEHU, 1983.
- Local influence upon the Ahoms. *Proceedings of NEIHA*, 6th session. Shillong : Dept. of History, NEHU, 1985.
- Sills, D.L (ed). *The International Encyclopaedia Of Social Sciences*. Vol.I : 21-6. New York : The Macmillan Company & the Free Press, 1968.
- Spier, L. *The Prophet Dance of North-west and Its Derivatives : The Source of the Ghost Dance*. Menasha, Wis. : Banta, 1935.
- Tran-Quoc-Vuong. The Tay-Thai contribution to the formation and development of Vietnamese culture. Paper presented at the *International Conference On Thai Studies*, Hanoi : Hanoi University, 1984.
- Wilson, M.H. *Reaction to Conquest : Effects of Contact with Europeans on the Fonso of South Africa*. 2d ed. London : Oxford Univ. Press, 1936/1961.

APPENDIX :

- * Sketches
- * Photographs
- * Genealogies

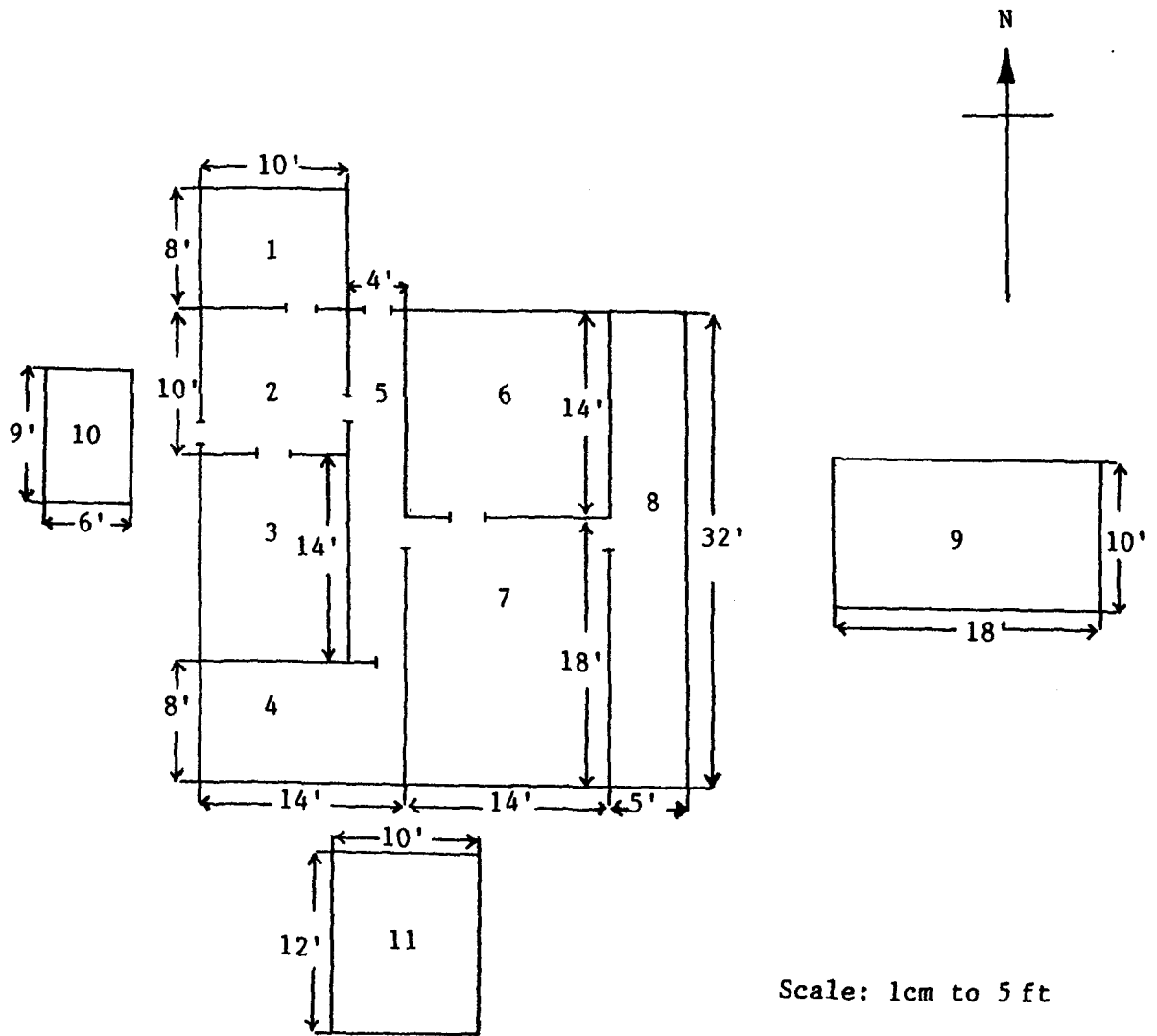

1. Main kitchen (Majia)
2. Subsidiary kitchen (Juihal)
3. Bedroom (Suwani kotha)
4. Paddy husking room (Dheki-hal)
5. Corridor
6. Bedroom
7. Living room (Bor-ghar)
8. Verandah
9. Granary (Bhadal)
10. Poultry (Gadal)
11. Cow shed (Guhali)

Fig I: An Ahom house plan

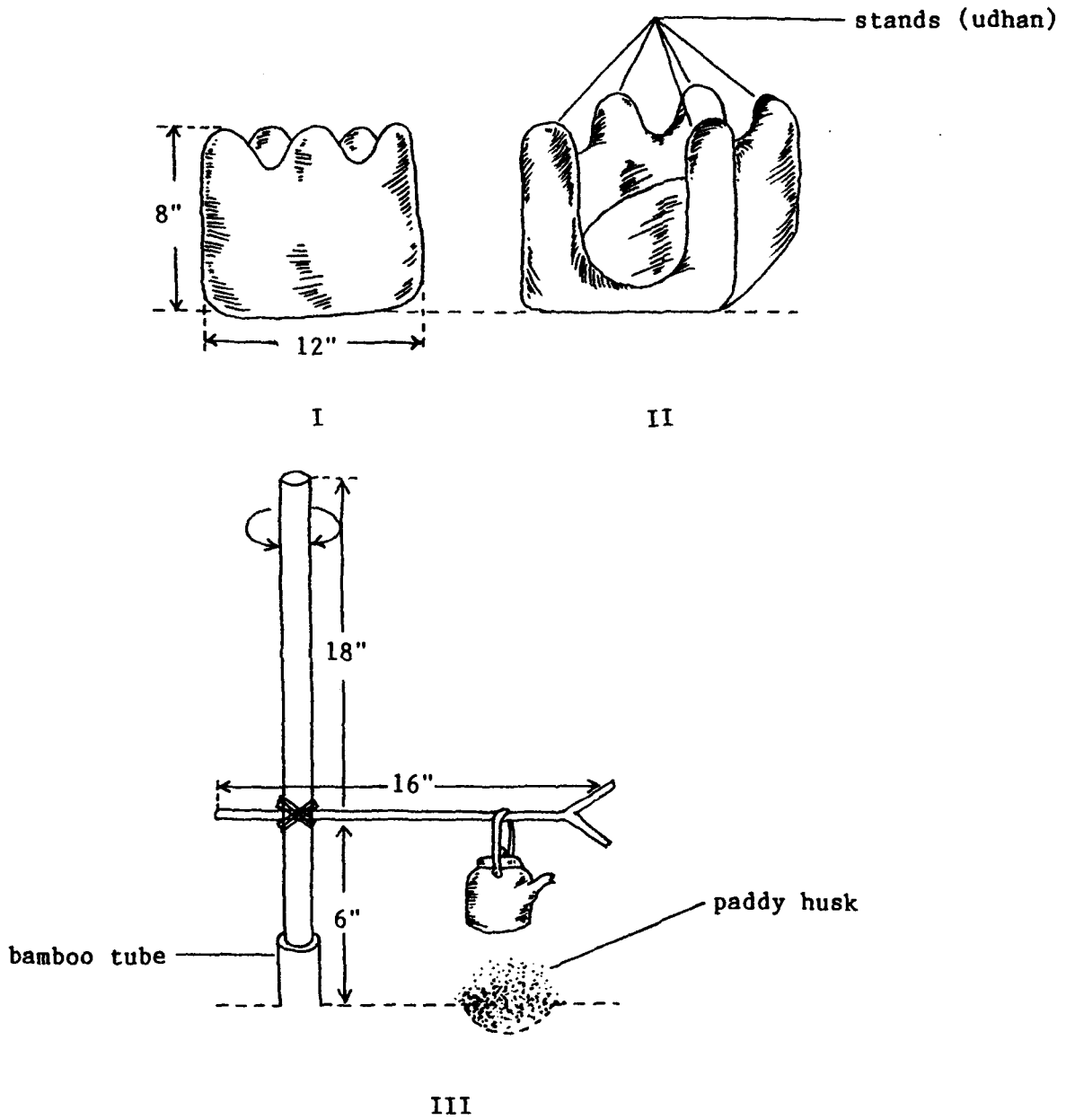
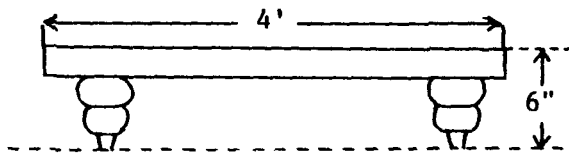
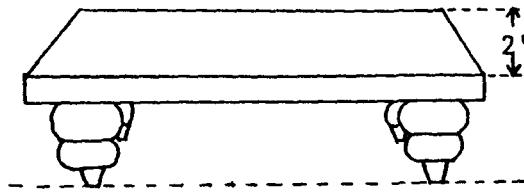

Fig II: I & II - Family hearth in the main kitchen (Majia)
 III - Make shift hearth in the subsidiary kitchen (Juihal)



I



II

Fig IV: I & II - Tamuli-pira

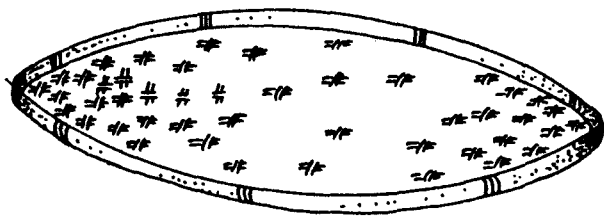
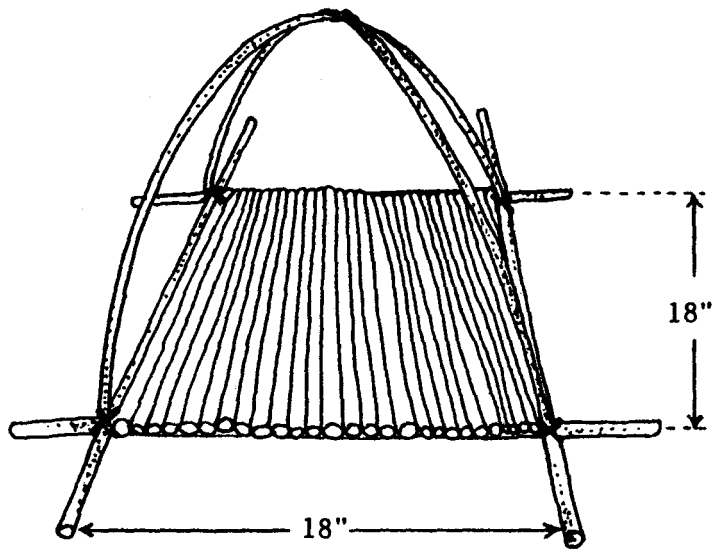
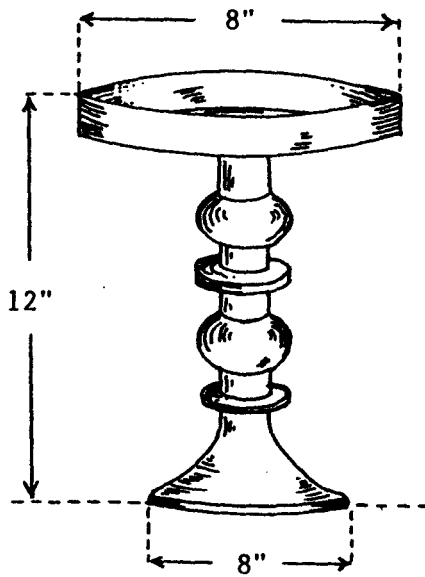

Fig V: Winnowing tray (kula)



I



II

Fig III: I - Karani (bamboo)
II - Xarai (bell metal)

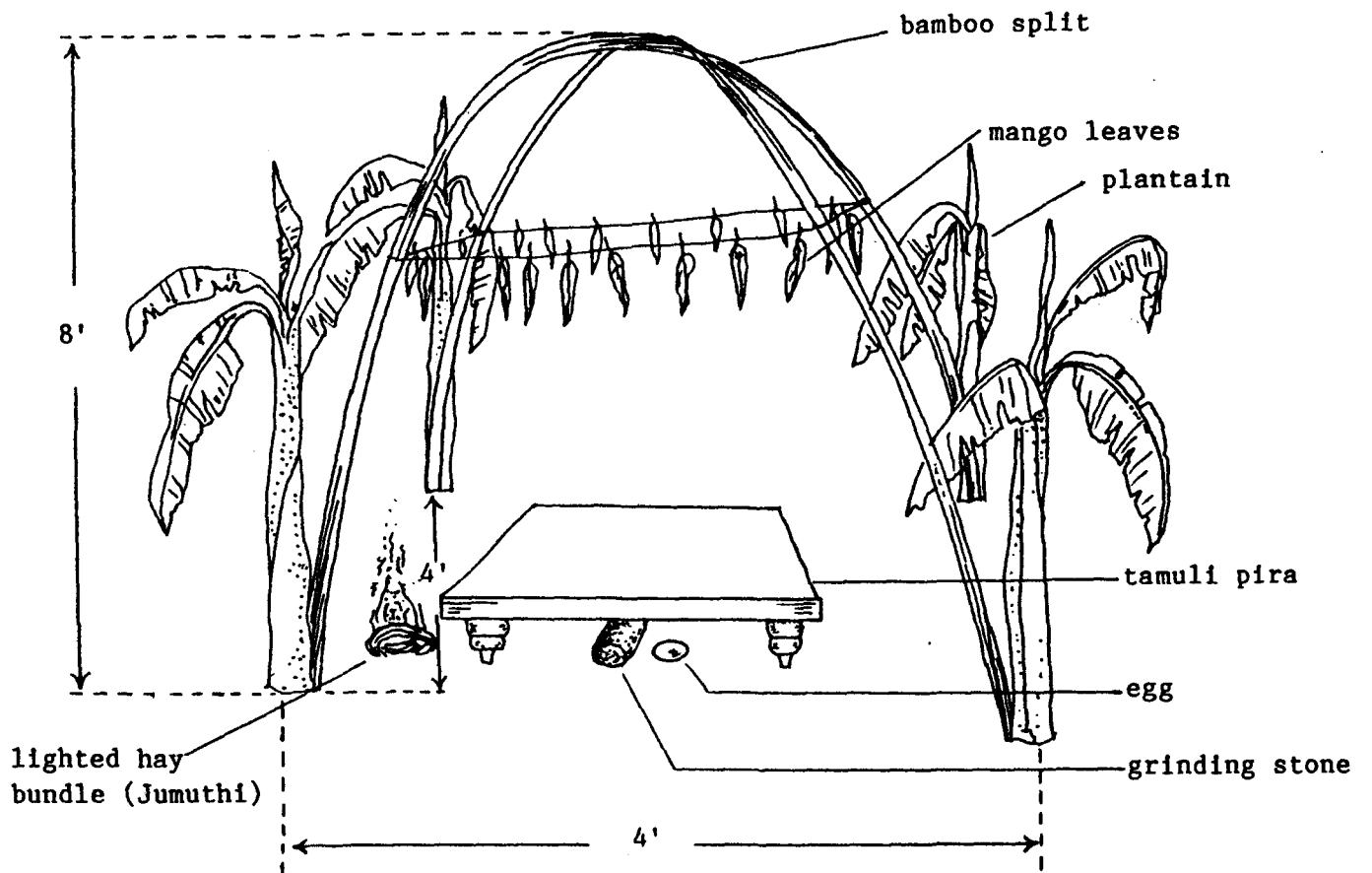

Fig VI: Bei for ceremonial bath (Nuowa)



Plate I
Murat-tell-diya: the mother applies oil on the hair of her son
who is being married.



Plate II (a/b)
Nuoa & Aptang: Paste of turmeric and black pulse are being applied on the groom before the ceremonial bath.



Plate III
Chaklang-maral: the altar for Chaklang ritual. 101 earthen lamps
denote a gathering of a large number of gods and goddesses to
witness and bless the couple.



Plate IV
Katha-bujani: Lessons on rights and duties on marriage are being imparted to the couple.



Plate V
The ritual offering of a sword to the groom by the bride.



Plate VI
The ritual offering of a shawl to the groom.



Plate VII
The groom applies vermillion on the bride's forehead.



Plate VIII
Exchange of garlands between the groom and the bride.

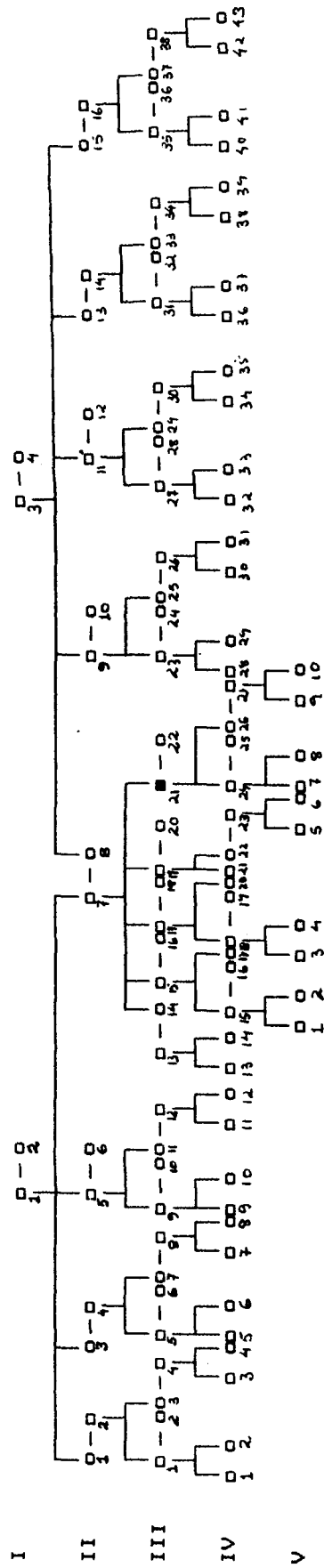

Plate IX
A game being played by the couple.

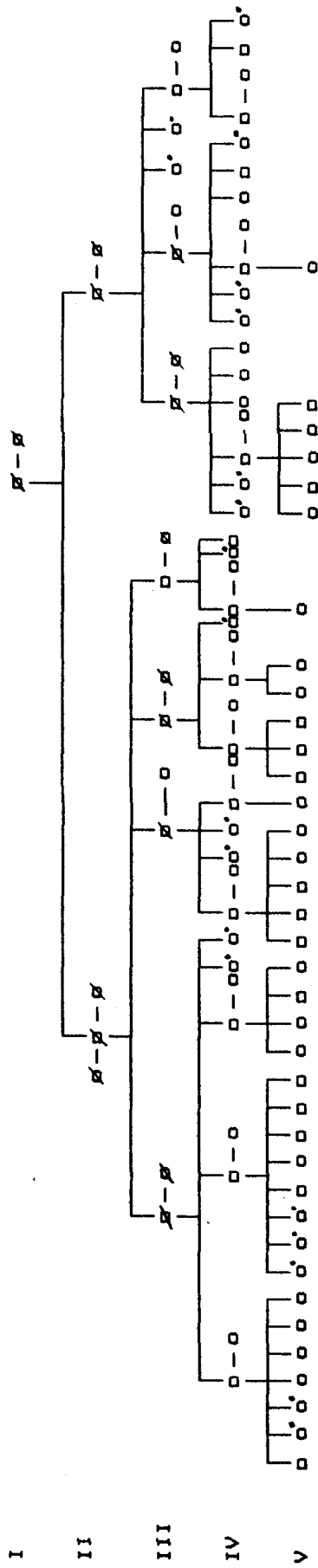

Plate X
Ritual offering of jalpan.

Genealogy of the Ahoms showing the co-lateral relations and the terms of address and reference.



GENEALOGY NO.1 : Descent Group No.1. Khe1-A/Pocket-I.



o = Married out.

♂ = Dead.

♀ = Dead.

GENEALOGY NO.II. : Descent Group No.II.Khel-A/Pocket-I.

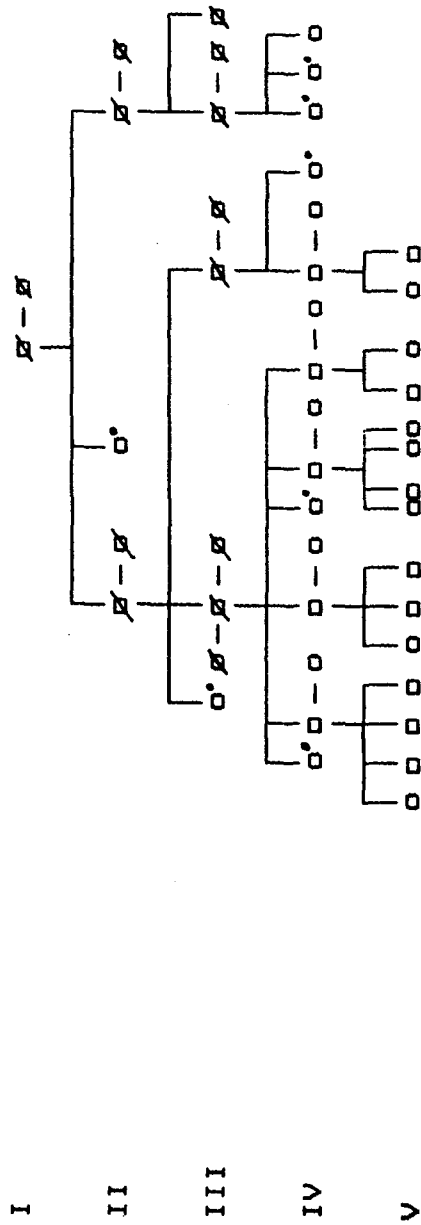

o = Married out
 ⊘ = Dead
 □ = Dead

GENEALOGY NO.III : Descent Group No.III.Khel-A/Pocket-I.

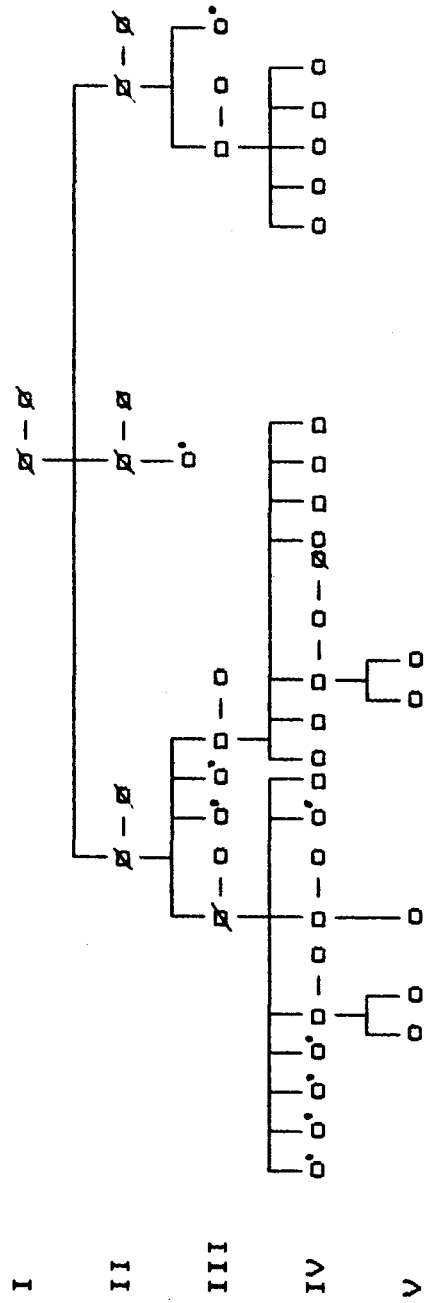

o' = Married out

♂ = Dead

♀ = Dead

GENEALOGY NO.IV : Descent Group No.IV.Khel-A/Pocket-I



♂ = Married out

♂ = Dead

♀ = Dead

♂ (Generation I/No.1) = Sapania; married to descent group No.II, generation VI, No.14.

GENEALOGY NO.V.= Descent Group No.V. Khe1-A/Pocket-I.

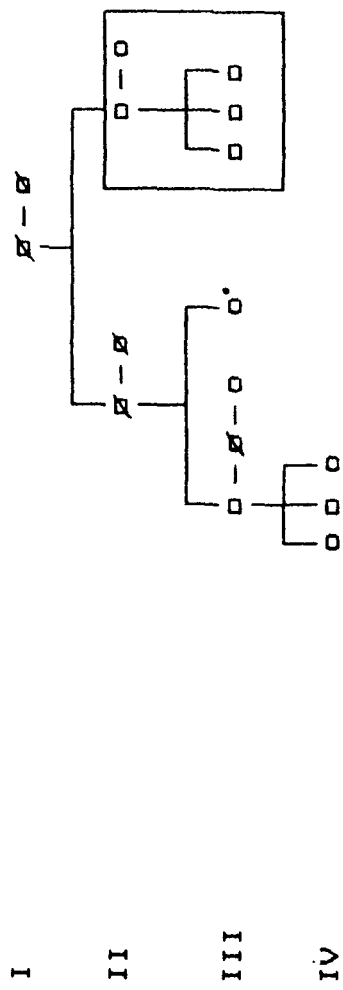

∅' = Married out

∅ = Dead

∅ = Dead

= Moved out of the village.

GENEALOGY NO.VI. : Descent Group No.VI. Khe1-A/Pocket-II.

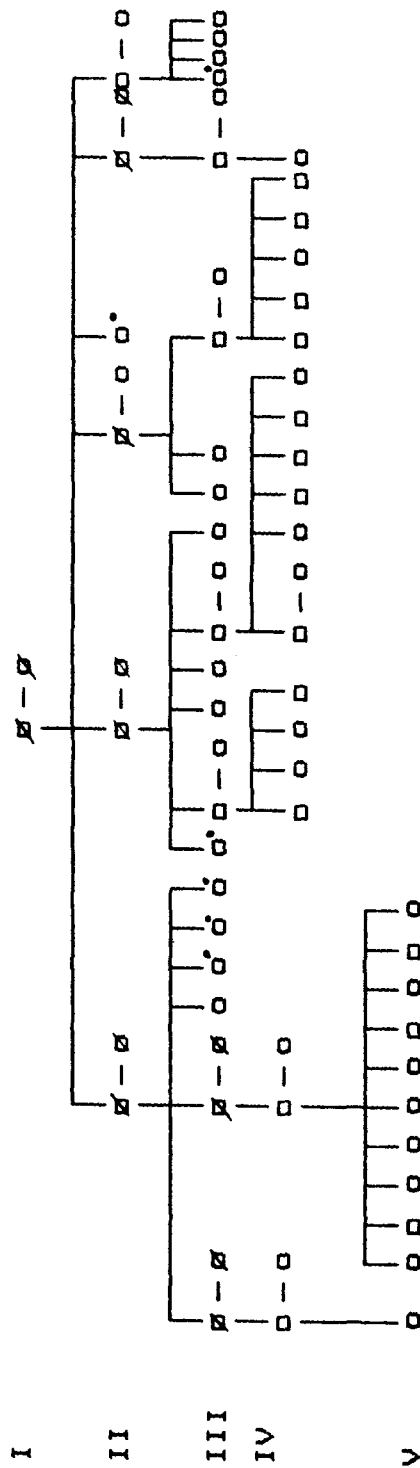

o' = Married out

♂ = Dead

♂:: = Dead

GENEALOGY NO.VII.: Descent Group No.VII. Khel-A/Pocket-II.

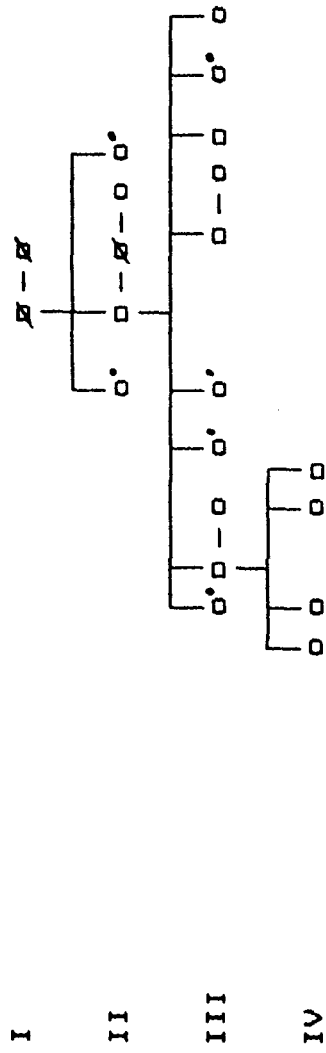

o' = Married out

♂ = Dead

♂ = Dead

GENEALOGY NO.VIII. : Descent Group No.VIII. Khel-A/Pocket-II.

I

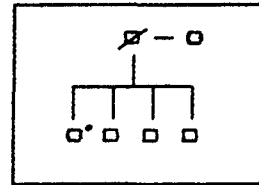

II

o' = Married out

∅ = Dead

∅ = Dead



= This 'group' does not have any 'localized lineage'.
The family had migrated in from other village.

GENEALOGY NO. IX. : Descent Group No. IX. Khei-A/Pocket-II.

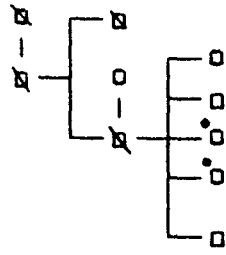

I

II

III

o' = Married out

♂ = Dead

♀ = Dead

GENEALOGY NO.X. : Descent Group No.X. Khel-B/Pocket-III.

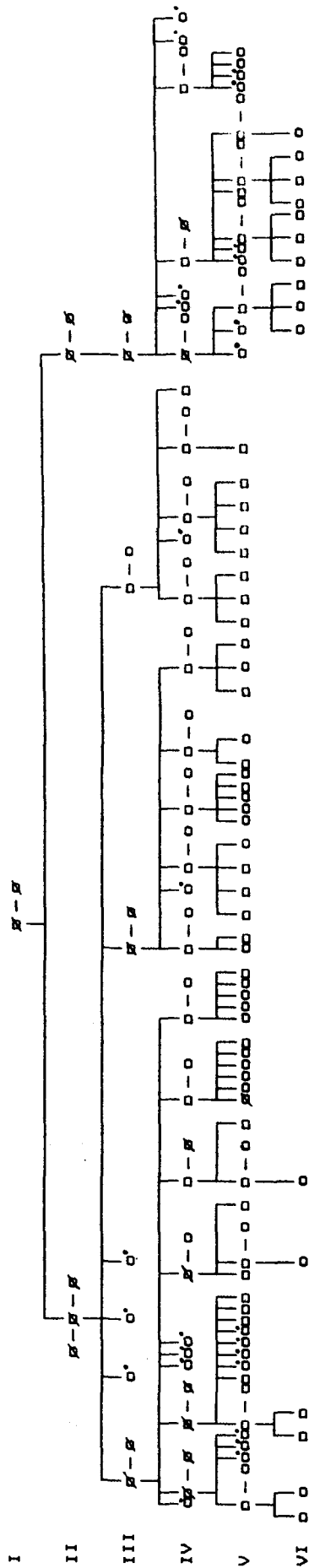

♂ = Married out
 ♀ = Dead
 ♂ = Dead

GENEALOGY NO. XI. : Descent Group No. XI. Khel-B/Pocket-III.

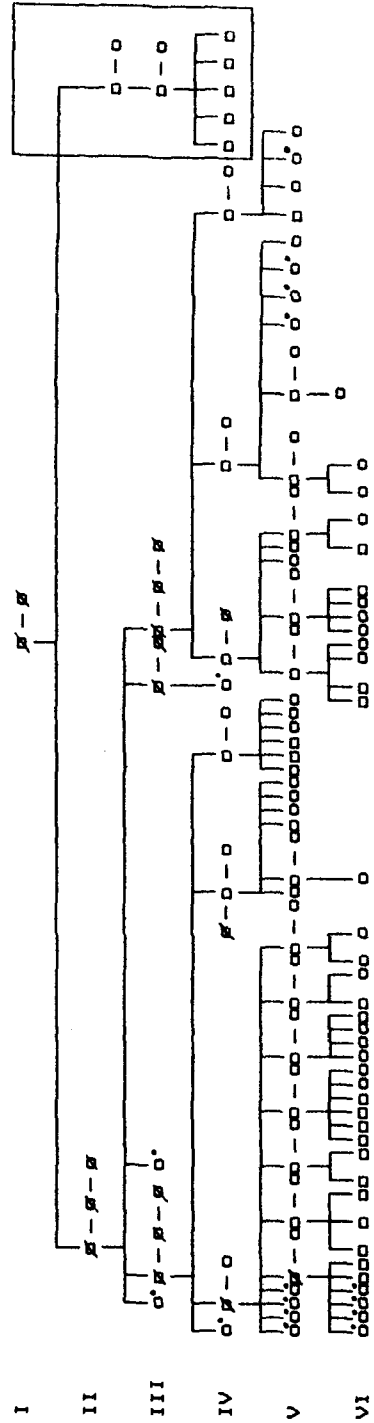

o' = Married out

♂ = Dead

♂' = Dead

□ = Moved out of the village.

GENEALOGY NO.XII. : Descent Group No.XII. Khel-B/Pocket-III.

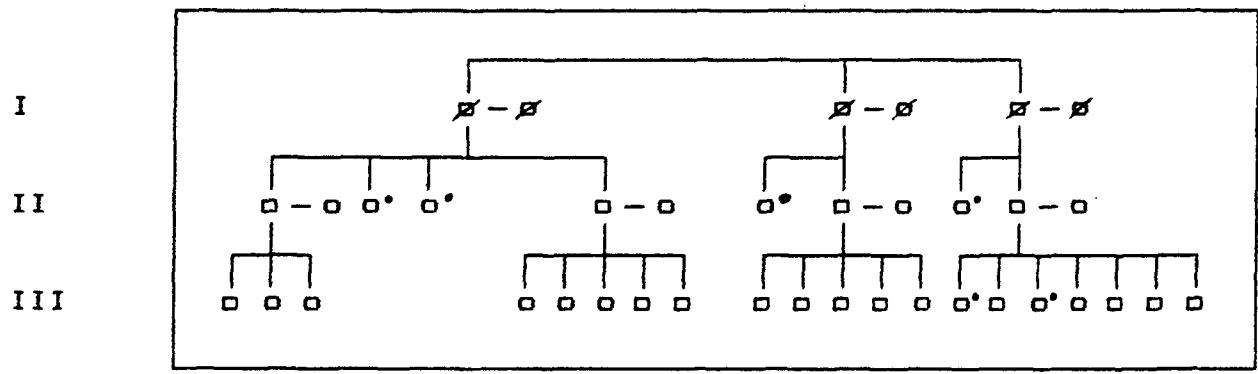

◦ = Married out

♁ = Dead

♁ = Dead



= This group migrated in from other village.

GENEALOGY NO.XIII. - Descent Group No.XIII. Khel-B/Pocket-III.

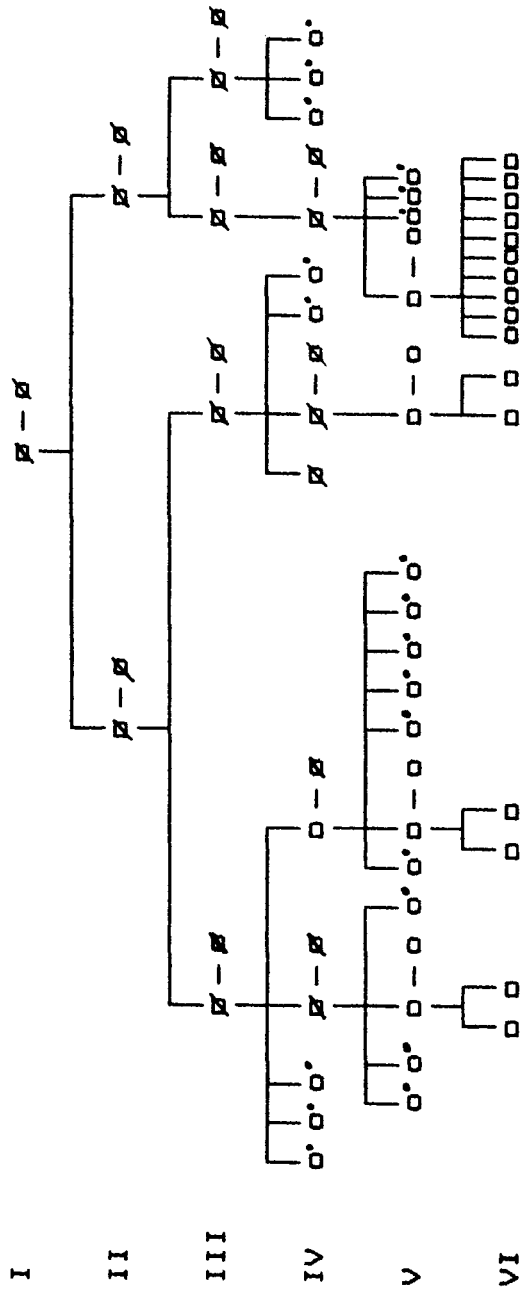

o' = Married out
 ♂ = Dead
 ♀ = Dead

GENEALOGY NO.XIV. : Descent Group No.XIV. Khel-B/Pocket-III.

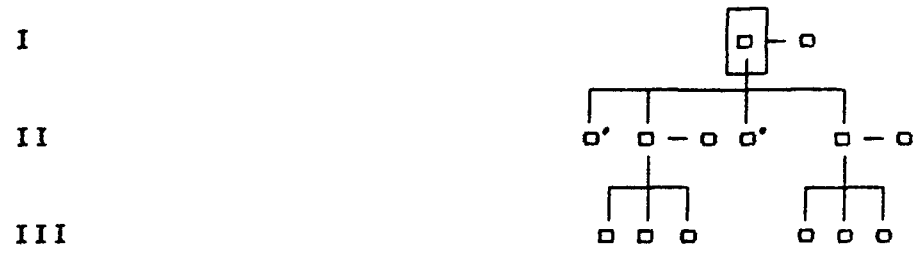

o' = Married out

o- = Dead

o = Dead

o = Sapania; married to No.2, Descent group No.XV, generation III.

GENEALOGY NO. XV : Descent Group No. XV. Khe1-B/Pocket-III.

I

II

III

IV

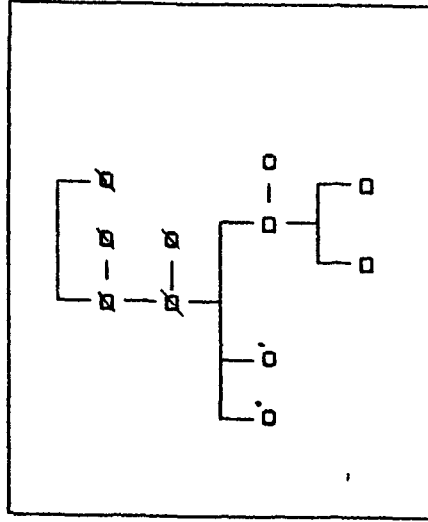

o' = Married out

∅ = Dead

∅ = Dead

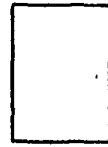

= This group migrated in from other village.